

MSU Extension Publication Archive

Archive copy of publication, do not use for current recommendations. Up-to-date information about many topics can be obtained from your local Extension office.

Tractor Project Unit 3: Improving Your Skills
Michigan State University Cooperative Extension Service
4-H Club Bulletin
N.A.
Issued May, 1970
72 pages

The PDF file was provided courtesy of the Michigan State University Library

Scroll down to view the publication.

1940

754

~~1940~~

ALLEGAN COUNTY
COOPERATIVE EXTENSION SERVICE

Agriculture — Home Economics — 4-H
County Building, Allegan, Mich. 49010

PETROLEUM POWER PROGRAM

TRACTOR 3

Improving Your Skills

THE 4-H TRACTOR CARE AND SAFETY PROGRAM

FIRST YEAR — TRACTOR PROJECT

Units

1. Learning How to Be Safe
2. What Makes an Engine Run
3. Nuts, Bolts, Screws, and Rivets
4. The Instrument Panel
5. Controls for Your Tractor
6. Daily Maintenance and Safety Check
7. Starting and Stopping Your Tractor
8. Clean Air for Your Engine
9. Periodic Lubrication and Maintenance

THIRD YEAR — TRACTOR PROJECT

Units

1. Tractor Safety on the Highway
2. Engine Ignition Systems
3. Hitches, PTO, and Hydraulic Controls
4. Steering, Brakes, and Front Wheels
5. Valves and Valve Service
6. Power Transmissions
7. Winter Care and Trouble Shooting
8. Tractor Records and Ownership Costs

SECOND YEAR — TRACTOR PROJECT

Units

1. Tractor Safety on the Farm
2. Oil for the Engine
3. Mixing Fuel and Air
4. Battery Service and Spark Plugs
5. Cooling Systems for Engines
6. Care of Tires
7. General Lubrication
8. Tractor Records and Operating Costs

FOURTH AND ADVANCED YEARS — MACHINERY PROJECTS

Units

1. Safe Use of Farm Machinery
2. Transmitting Power
3. Tools For Breaking The Soil
4. Applicators For Chemicals
5. Servicing Seed Planters
6. Cutters for Crops
7. Seed Separation
8. Farm Machinery Management

4-H TRACTOR PROGRAM

THIRD YEAR

TRACTOR CARE AND SAFETY

This is the third in a series of four project books in the 4-H Tractor Program. It is intended for your use after you have completed the First and Second Year Project books. By doing the demonstrations and jobs outlined, you will learn more about tractor care and safety.

The purpose of the 4-H Tractor Program is to give you an opportunity to “learn by doing.” You will learn that better tractor care results in longer tractor life, more power, and lower operating costs. Because you learn how to do many small but important tractor maintenance jobs, you will get better production from farm power units and you will cut down on costly breakdowns.

While you are learning how to care for your tractor you should also learn how to be a safe operator. Another important goal of this program is to help you form good safety habits so that you can think and act safely—at all times.

Equally important with learning tractor care and safety is the 4-H goal of helping you to become a sound-thinking citizen. The training you receive in your 4-H program will be very beneficial to you throughout your lifetime.

Take time to read carefully the informative material in each unit. Go through the work units slowly and carefully, and complete the demonstrations and jobs outlined. The greater the interest and effort you give to your 4-H project, the greater will be its reward to you.

Ask your leader about Unit 8 on record keeping and ownership costs. He may want you to start on this unit right away.

DETAILS ABOUT WHAT YOU DO ARE ON THE FOLLOWING PAGES

Good Luck!



Note: In completing your 4-H Tractor Project at the close of the club year it is suggested that you submit only the following pages:

Member's Summary (page 3)

Completed Work Units (the yellow sheets)

Completed Check-Up Sheets (the blue sheets)

My Achievements and
Experiences (in back of book)

This is my 4-H Tractor Book

.....

4-H TRACTOR CARE AND SAFETY PROJECT THIRD YEAR



WHAT TO DO

Your 4-H Tractor Program has four parts. The First-Year Project lets you get acquainted with your tractor and learn about the importance of tractor safety. The Second and Third Year Projects cover tractor care and safety. The Fourth book covers machinery care and safety. It can be divided into two or more project years according to the machines you have on your farm. Safety is always important. That's why it is included in all four books.

For each year's project there is a booklet like this one. This booklet and your Operator's Manual will give you the answers to most of your questions. The white sheets in each unit give you correct general information and are illustrated with drawings to help you. Read each paragraph carefully. Study your Operator's Manual and put into practice what you learn by actually working with a tractor.

On the yellow work unit sheets, record the jobs that you finish. The more jobs you do, the more you will learn and enjoy this work. There are also some questions for you to answer.

Be sure to answer all of the work unit questions that apply to your tractor. Some of the questions are about diesel and propane tractors. If you find the information in the white sheets, fill in the answers. If you are not working on a propane or diesel engine, and the answer isn't given in the white sheets, you don't need to answer the questions.

Be sure to answer the blue check-up sheets. All you have to do is put the letter for the correct answer at the right of the page. Be on your toes. Read each question carefully before giving your answer.

YOUR RECIPE FOR SUCCESS

Keep your records up to date as you complete each work unit. There are honors and awards for those who do the best work. You will want to do some of the following in addition to filling out the work units:

Give demonstrations and talks on tractor care and safety.

Take part in local and county tractor operators' contests.

Encourage other boys to enroll in the club.

Become a junior leader and help your leader to assist others or younger members.

Practice what you learn on your tractor at home. Remember, you should know the "why" as well as "how."

Submit only the Member's Summary, Work Units, Members' Check-Up Sheets, and story in this book to complete your project and club year. Do not submit the entire book.

Continue your tractor projects by enrolling for next year's work.

HONORS AND AWARDS

The top four winners in the 4-H Tractor Program in your county can receive gold medals. The state winner in your state receives an all-expense trip to the National 4-H Congress in Chicago. You may even win one of the \$500 scholarships that are awarded to national winners. In addition, you can receive honors and awards in tractor operators' contests or for demonstrations you give or exhibits you make.

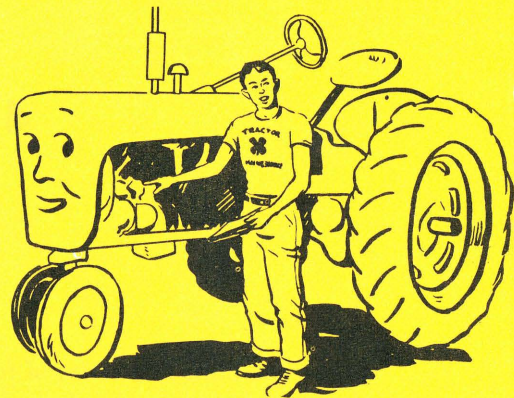

Fig. 1 Learning by demonstrating.

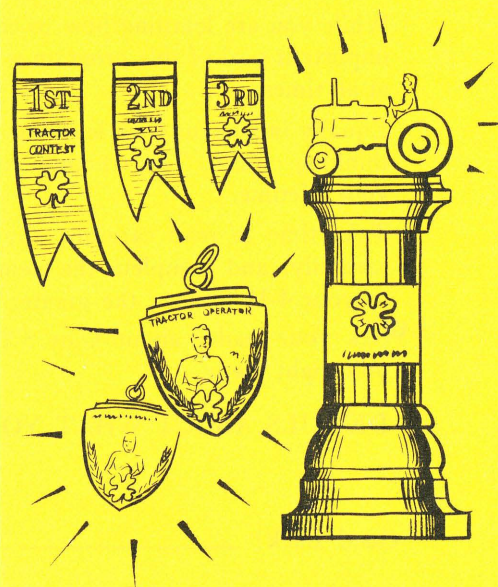

Fig. 2 Awards for 4-H achievements.

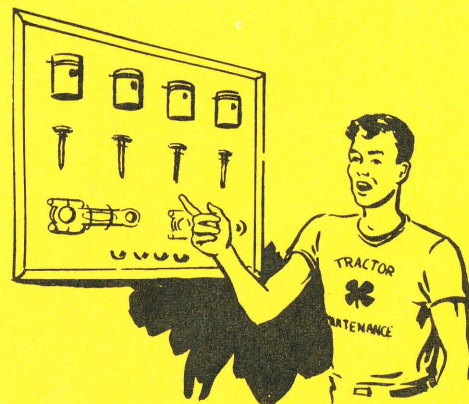

Fig. 3 Display of damaged parts.



MEMBER'S SUMMARY

THIRD YEAR

TRACTOR CARE AND SAFETY



Name _____ Age _____ Years in 4-H _____

Address _____ County _____ State _____

Name of Club _____ Name of Leader _____

Date and Place of Meetings	<i>1. Tractor Safety on the Highway</i>	<i>2. Engine Ignition Systems</i>	<i>3. Hitches, PTO, and Hydraulic Controls</i>	<i>4. Steering, Brakes, and Front Wheels</i>	<i>5. Valves and Valve Service</i>	<i>6. Power Transmissions</i>	<i>7. Winter Care and Trouble Shooting</i>	<i>8. Tractor Records and Ownership Costs</i>
1. _____								
2. _____								
3. _____								
4. _____								
5. _____								
6. _____								
Date meeting held								
Did you attend?								
Date work unit completed								
Date check-up sheet completed								

DEMONSTRATIONS: Where? When? Topic? _____

TRACTOR OPERATING CONTESTS: Date? Where? Placing? _____

OTHER EVENTS: Exhibits, Tours, etc. _____



THIRD YEAR



4-H TRACTOR CARE AND SAFETY PROJECT

COMPLETED _____
(Date) (Signature of member)

COMMENTS OF CLUB LEADER

Date _____
(Signature)

COMMENTS OF COUNTY EXTENSION AGENT

Date _____
(Signature)

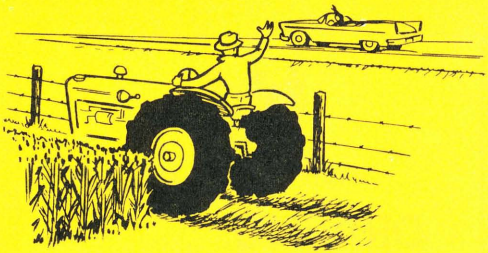

Fig. 1 Use your field instead of the road.

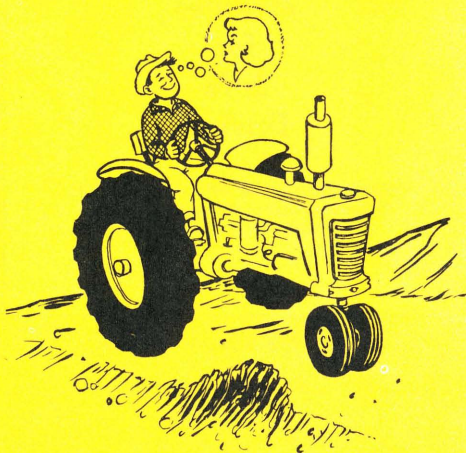

Fig. 2 Watch for obstructions that could cause an upset.

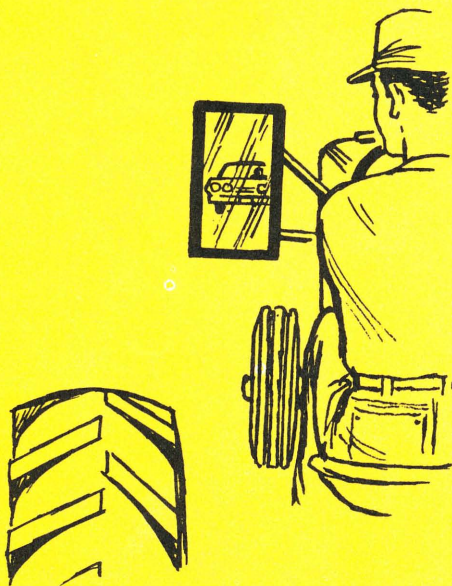

Fig. 3 Use a rear-view mirror.



Fig. 4 Stopping distances for a car going 60 miles per hour.

About one-third of all fatal tractor accidents occur off the farm. Collisions with motor vehicles take a heavy toll, but many off-the-farm tractor accidents do not involve a collision but rather are caused by other factors such as upsets, loss of control, and falls by extra riders.

Only an experienced operator should be permitted to operate farm equipment on public roads. Don't ask your younger brother to drive the tractor to the house for you. The best way to prevent accidents is to avoid using the roads more than is absolutely necessary. Use the lanes or headlands in your fields whenever possible. If you must use a highway or road, arrange to travel when traffic is the lightest and be alert to prevent accidents.

TRACTORS ARE NOT BUILT FOR HIGHWAYS

Your tractor was not intended for use on highways and public roads. For one thing, even when traveling in road gear its speed is much slower than motor vehicle traffic and it is a set-up for an accident, like a "sitting duck" in a shooting gallery. There are several dangerous things that can happen to a tractor on the highway, even without becoming involved with other traffic. It can hit an obstruction and upset, or it can go out of control and wind up in the ditch. And the highway is certainly no place to give someone a ride on your tractor. There is no safe place on a tractor for anyone but the operator. While on the highway you can't hear other traffic because of the noise your tractor engine makes, so that leaves only your eyes to warn you of other traffic. But your vision is limited to watching the road ahead. If you have to use the highway very often you might want to install a large rear-view mirror to let you watch for traffic in both directions.

In traffic studies of collisions involving a tractor and a car or truck, the tractor operator is usually the one who becomes a fatality. Your tractor gives you almost no protection against injury. If you should collide with a car or other motor vehicles, you have a good chance of being pinned under the tractor or thrown violently from the seat.

SPEED AND IDENTIFICATION ARE PROBLEMS

Many motorists who have been involved in accidents with tractors have reported that they failed to identify the tractor or were not aware of its presence until it was too late. The tractor may have been visible but not moving at a speed fast enough to cause notice. Let's look at a typical accident situation.

A car is traveling down the highway at 60 miles per hour, which is equal to 88 feet per second. If you were to pull out on the highway with your tractor when the car is 1/16 of a mile (330 feet) down the road, the driver of the car has less than 4 seconds to see you and bring his car under control. Suppose he doesn't see you for 1 second. That brings him 88 feet closer and leaves only 3 seconds. It may take him another 1½ seconds to collect his thoughts, decide what to do and start to apply the brakes. By this time he is only 110 feet away, but he needs a least 200 feet to bring his car to a full stop. A collision and serious accident are almost a certainty. Check traffic carefully before pulling onto the highway with your tractor.

TRACTOR SAFETY ON THE HIGHWAY



STATE LAWS RELATING TO FARM EQUIPMENT

There are certain laws in your state that apply to the operation of farm equipment on public roads. These laws cover the operation, lighting, and identification of farm equipment on public roads and vary from one state to the next. To obtain the information on the laws that apply to your state, check with your local state police. Perhaps they can furnish you with a copy of the traffic laws for farm equipment. This information would make a good report for your next club meeting.

SAFE DAYTIME DRIVING

Avoid the use of busy highways even if it means you must drive a long way out of your way. If you have to use a two-lane highway, drive on the shoulder if possible and go slowly enough to see obstructions or holes that could cause an upset. Sometimes you have no choice but to use the highway surface. When you do, avoid the dangerous practice of driving with one wheel on the pavement and the other on the shoulder. This practice encourages faster traffic to try to pass when there isn't enough room. If oncoming traffic doesn't yield part of its lane, the car attempting to pass will crowd the tractor off the highway or side-swipe it, catching the left rear wheel. It is better to occupy one full lane the same as if you were driving a car. At least this will help to keep cars from passing you without first making sure there is no oncoming traffic.

Hilly, winding roads are especially hazardous because the driver of an oncoming vehicle cannot see you and you cannot see him. As a result there may be a collision or someone has to take to the ditch.

The best way to avoid highway accidents is to stay off the road as much as possible. If you must use the highway, use it when traffic is the lightest, and make your equipment as easy to identify as possible. Some states require the use of warning flags. This is a good idea even if your state doesn't require it. Use a bright red or orange flag at least 18 inches square and attach it to a pole so it is displayed well above the tractor. A similar flag should be used on equipment the tractor is pulling.

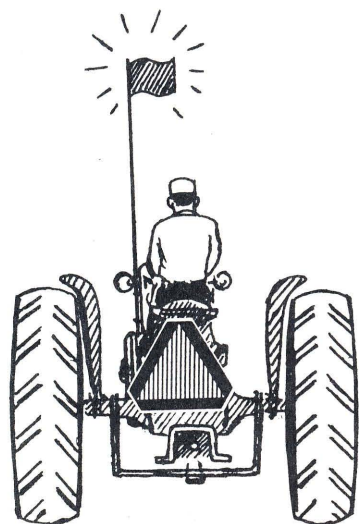

Fig. 8 Identify your tractor as a slow-moving vehicle. The triangle is a reflector for both daytime and nighttime use.

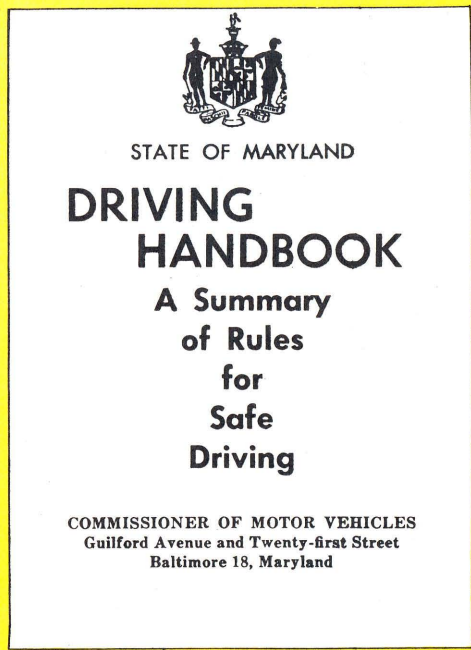

Fig. 5 Know your state laws.

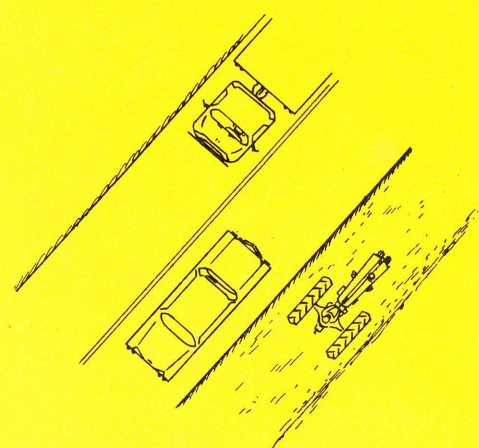

Fig. 6 Drive on the shoulder if there is plenty of room.

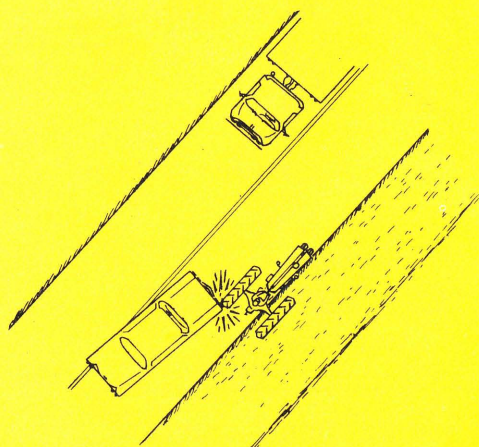

Fig. 7 A dangerous practice that can lead to accidents.



Fig. 9 Courtesy is the key to safety.

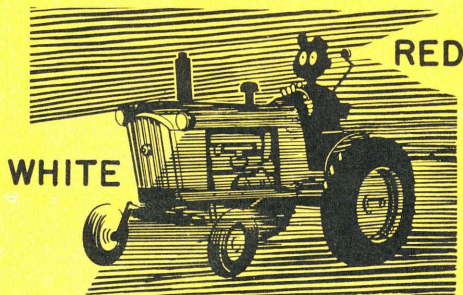

Fig. 10 Use proper lighting for night-time driving.

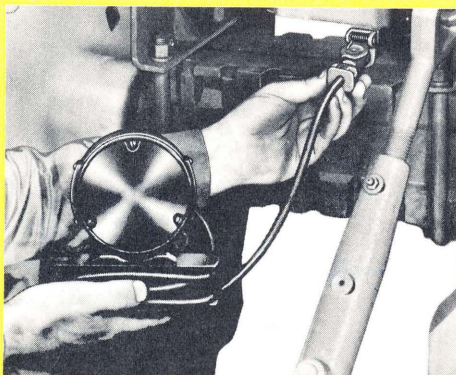

Fig. 11 Extending a light for mounting on a towed implement.

PRACTICE COURTESY

Safety on the highway begins with courtesy. When traffic piles up behind you, pull off the road at the first opportunity and let it pass. Remember that it is a privilege for you to operate your tractor and equipment on a highway. Don't abuse this privilege. Practice courtesy. Know and obey the rules of the road as they apply to the tractor and other slow-moving equipment in your state.

SAFE DRIVING AT NIGHT

Operating your farm equipment on a highway at night presents a serious problem since it is difficult for motorists to know of your presence. The best rule is to stay off the highway at night with slow-moving equipment. Plan your work so that your equipment is moved during the daylight hours and at a time when traffic is lightest.

If you must travel at night, be sure your tractor is provided with adequate lights, and that supplemental lighting is provided for the towed equipment. Your local state laws should be followed in the lighting of your equipment. You may find that they are similar to the laws suggested by the Uniform Vehicle Code. This Code states that tractors should have one or two white lights visible 500 feet forward, and a red light visible 500 feet to the rear. It is dangerous to use a white light to the rear because it might cause a motorist to think the light is the headlight of an oncoming car. It is also dangerous, and sometimes even illegal, to use a flashing red light. In many localities a flashing red light has been reserved for use on emergency vehicles such as ambulances and police cars.

If equipment is towed by the tractor there should be an additional red light visible 500 feet to the rear and located to indicate the farthest projection of any part of the equipment to the side of traffic. In addition, red tail lights or reflective tape can be applied to the extreme right and left corners of the towed equipment. Lights, electrical connections, and mounting brackets for lighting farm equipment have been standardized so they can be used on all combinations of tractors and equipment.

BLIND CORNERS

One of the major hazards in rural areas is blind intersections and driveway entrances that have growing crops or shrubbery that restrict vision toward the other lanes of traffic. Check with your leader. Perhaps your club could make a project of clearing some of the blind corners in your community. Be sure you first obtain permission from the landowners and tenants. Clear your driveway so that visibility is extended for at least 700 feet in both directions.

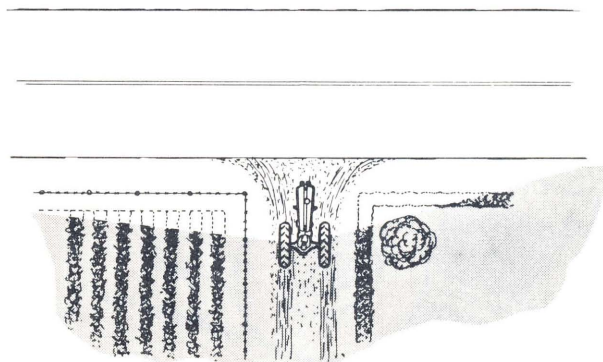

Fig. 12 Keep driveways clear of shrubbery and growing crops.



TRACTOR SAFETY ON THE HIGHWAY

SAFE EQUIPMENT

In the First and Second Year projects you learned about the importance of keeping your equipment in safe operating condition. It is even more important to have your equipment in safe condition when it is taken onto the highway.

When you travel on highways or public roads you are traveling at speeds much faster than you would use for field work. This means that the mechanical condition of your tractor must be perfect. A routine daily safety inspection is the best way to find and eliminate hazards before they can cause trouble. Be particularly alert for loose or missing bolts and nuts in the wheels, and check for cracks in the wheel castings. Take a good look at the tires to make sure they are suitable for use on the highway. Check the tire pressure.

Inspect the steering mechanism for loose play. You may not have noticed it in the field, but it doesn't take much looseness to cause trouble on the highway.

In normal field use, brakes do not always wear evenly. This is because the tractor is usually turned more in one direction than the other. If the brakes are not adjusted evenly, applying both brakes in a sudden stop could cause the tractor to upset. Adjustment of the brakes is discussed in this book in Unit 4 "Steering, Brakes, and Front Wheels."

Tractors can pull far more weight than they can safely stop in an emergency. If you are pulling a heavy load behind your tractor, drive slower and allow plenty of distance for stopping when approaching an intersection or stop sign. As a safety precaution, start slowing down far enough ahead so that a complete stop can be made without the brakes.

Use great care when stopping a tractor with a load behind. It takes only a little braking pressure on the load to cause the hitch to jackknife and upset your tractor.

Your tractor tires may contain a liquid or other heavy ballast. If this is the case, be sure both tires are filled to the same level. If the load in the rear tires becomes unbalanced while the tractor is traveling at a high rate of speed, the tractor can go out of control. You may have to reduce speed in order to maintain control of your tractor.

Be careful when going down a hill or grade. Shift to a low gear before starting down a hill and leave the tractor in gear. **CAUTION**—Some of the transmissions in modern tractors will not hold a load in certain gears when going down a grade. Check your Operator's Manual to see which gears can be used safely when going down a hill.

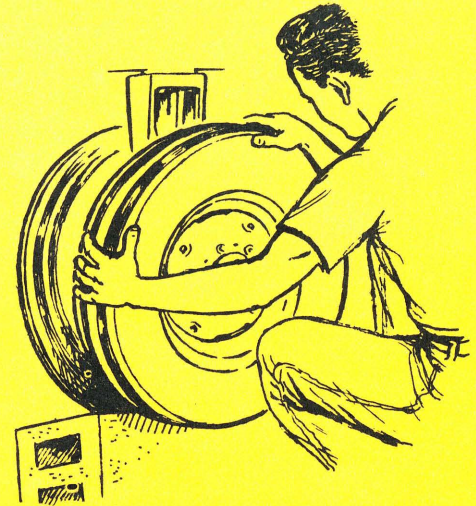

Fig. 13 Checking for loose steering. Is your tractor safe?

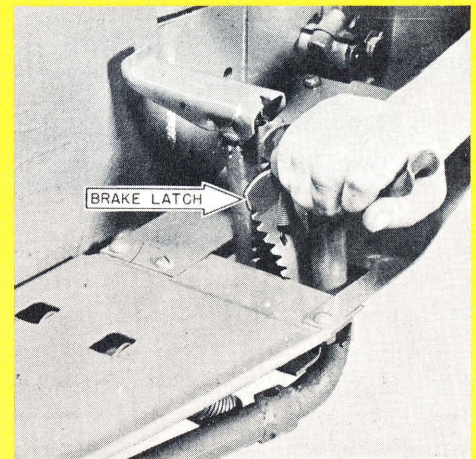

Fig. 14 Keep your brakes adjusted.

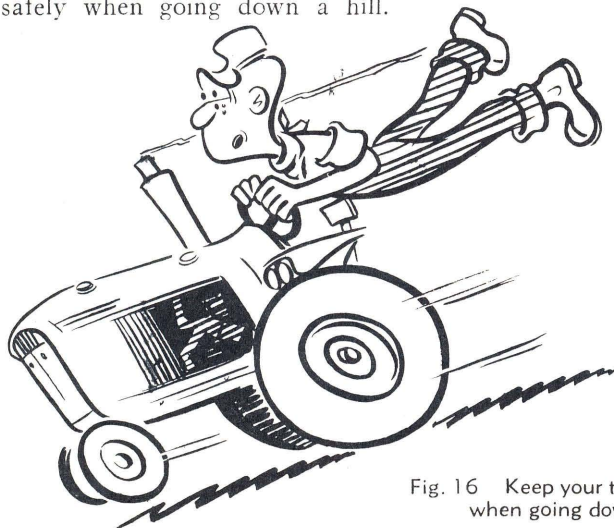

Fig. 16 Keep your tractor in gear when going down hill.



Fig. 15 You can't make a quick stop when pulling a load.



Safety Starts with Courtesy

Let's discuss some accident situations that have actually happened. Read the story of each accident and then discuss it with your leader and the other members. Use the blanks to tell us what you have learned that could help prevent a similar accident from happening to you.

Situation 1 Farmer A was pulling an empty wagon down a single-lane gravel road late at night. He was traveling about 18 miles an hour. When he met an oncoming car he pulled off to the side. The rear wheel dropped into a hole, upsetting the tractor. Farmer A was crushed under the tractor and died instantly.

How could this accident have been prevented? _____

Situation 2 Farmer B was driving down a highway with two wagonloads of potatoes behind his tractor. When he approached a stop sign and started to apply his brakes he saw a car coming from his right and realized that he might not be able to stop in time. He then jammed harder on the brakes, but they were not adjusted evenly and the tractor pulled sharply to the left. This caused the wagons to jackknife and upset the tractor. The motorist was able to stop safely but Farmer B was thrown from his tractor and suffered a broken arm and a skull fracture, narrowly escaping being crushed by his tractor.

How could this accident have been prevented? _____

Situation 3 Farmer C was returning home late at night after disking in a nearby field. He was driving down the road in front of his house. His tractor was equipped with one white light to the front but the only lights he had to the rear were reflectors on each end of the disk. A motorist came down the road behind him, saw the two reflectors and, thinking they were markers for bridge abutments, drove between them. As the car rammed into the disk, Farmer C fell in the path of the disk and died instantly.

How could this accident have been prevented? _____

Situation 4 A 16-year-old boy was returning a tractor that had been overhauled in the high school shop. Four other boys went along for the ride. During a little horseplay one of the boys fell from the tractor and caught his pant-leg on the hitch. He was dragged along the ground for about 50 feet before the tractor could be stopped. The boy suffered severe cuts and bruises and spent a week in the hospital.

How could this accident have been prevented? _____

1. Do you operate your tractor or other equipment on a rural road or highway? _____

How often? _____

List any dangerous situations that you have encountered. _____

2. Do you use safety warning flags? _____ Describe how they are used. _____

3. Do you use any special lighting on your tractor or equipment for travel at night? _____

Describe how you have lighted your equipment for travel at night. _____

4. Make a safety inspection of your tractor. Is it safe for operation on a highway? _____

Tell what you found that could cause an accident on the highway. How about the brakes? Steering?
Clutch? Tires? Wheels? _____

Don't wait. Correct any unsafe items right away.

5. Are there any gears on your tractor that should not be used when pulling a load down a hill? _____

Which ones? _____

6. How can you help reduce tractor accidents on highways and rural roads? _____

Note: Fill out this work unit, using your own tractor at home. Be ready to discuss your experiences with other 4-H members at your next club meeting.



THIRD YEAR UNIT 1

TRACTOR SAFETY ON THE HIGHWAY

Place the letter for the correct answer at the right of the page.

1. It is (A—more) (B—less) dangerous to move farm machinery on the highway than _____
to use it on the farm.
2. The stopping distance for a car going 60 miles per hour, including reaction time and _____
braking distance, is approximately (A—100 feet) (B—280 feet) (C—366 feet) for a
wet pavement.
3. The electrical socket on tractors for extending a warning light to a trailed implement _____
(A—is) (B—is not) standardized.
4. It is safer to (A—pull halfway off the road) (B—get completely off the road) if _____
someone tries to pass you on a two-lane highway.
5. The tractor, being a slow-moving vehicle, (A—always) (B—sometimes) (C—never) _____
has the right-of-way over cars.
6. The first step to operating a tractor on the highway is to (A—learn the traffic laws _____
which apply to your state) (B—learn to drive a car).
7. In a collision between a tractor and a car the driver of the (A—car) (B—tractor) is _____
more likely to become a fatality.
8. Lights on tractors should be visible for a distance of (A—200 feet) (B—1,500 feet) _____
(C—500 feet)
9. Safe operation of a tractor on a highway begins with (A—courtesy) (B—assuming _____
that others will look out for your safety).
10. Records show that most accidents are caused by (A—working when tired) (B—try- _____
ing to hurry) (C—taking chances) (D—not using what you have learned about being
a safe tractor operator).

Note: This Check-Up Sheet is intended to test what you have learned and to stimulate discussion with the other members. The more you discuss these questions with your leader and the other members the more you learn.

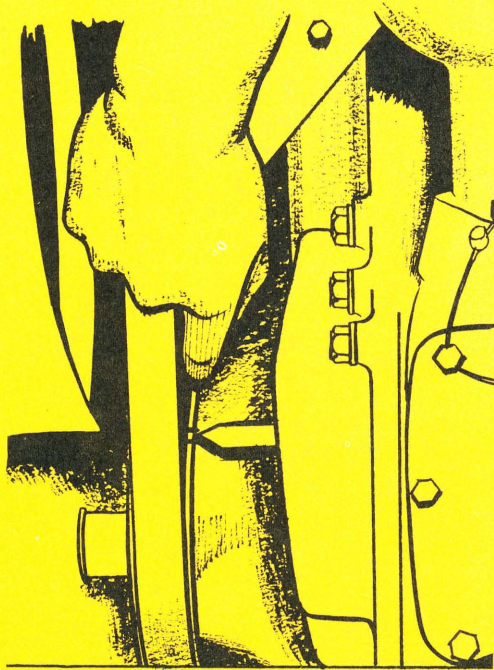

Fig. 2 This is a timing mark on a carburetor engine.



Fig. 3 You "lead" a rabbit so your bullet will hit him where he's going to be. A spark has to fire sooner when the engine is going faster.

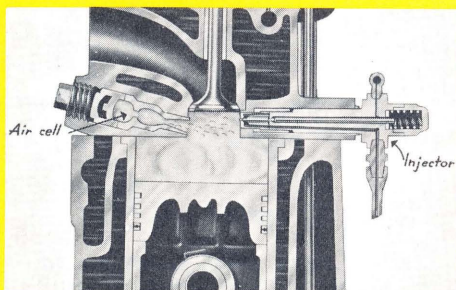

Fig. 4 In a diesel engine, ignition of the fuel is provided by the heat of compression.

You learned how to service spark plugs and care for the battery in the Second Year Project. These jobs need to be done regularly. Before starting other work on the electrical system, you should service the spark plugs and check the battery.

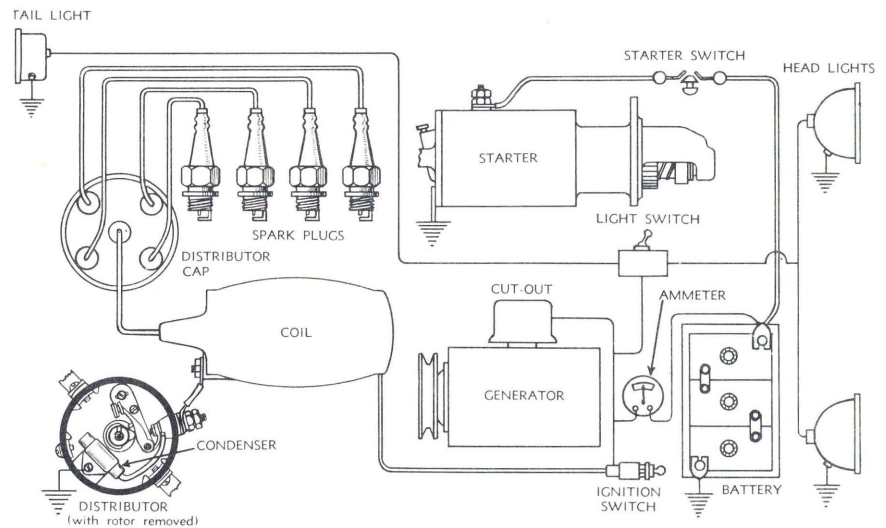

Fig. 1 A tractor electrical system.

IGNITION

In a carburetor engine, a mixture of fuel and air is compressed inside a cylinder. Then a high-voltage spark jumps across the spark plug gap to fire the charge. The spark must be strong enough to jump the gap and it must do so at just the right time. When you are cranking an engine, the piston moves up slowly. It must be near the top of the cylinder before the spark ignites the charge. If the spark occurs too soon the engine will run backward or "kick." To keep the engine from kicking, the spark must be retarded.

In a diesel engine, fuel ignites when it is sprayed into the cylinder which contains hot, highly compressed air; therefore, an electrical ignition system is not needed.

It takes about the same amount of time for the fuel to burn and build up pressure when the engine is running slowly or when it is running at full speed. At full speed, however, the piston is traveling rapidly and the spark must occur much sooner so the pressure from the burning fuel charge will come just as the piston starts down. We call this spark advance. The more the air and fuel mixture is compressed the faster it will burn. Therefore, a high-compression engine does not need as much spark advance as a low-compression engine. The ignition system is made so that it will retard the spark for starting, and advance it after the engine picks up speed.



BATTERY IGNITION SYSTEMS

Older tractors used a magneto ignition system that did not require a battery. The magneto is a little generator that makes its own electric current. After generating the current it uses a coil, breaker points, condenser, and distributor to provide a hot spark at the right time.

In a battery ignition system, electric current is supplied by a battery (charged by a generator). Otherwise, battery ignition systems have about the same kind of parts as the magneto system. They have a coil for changing low-voltage current to high-voltage, and a distributor for directing the sparking current to the proper spark plug.

The battery ignition system also has breaker points and the spark is generated as the points open. A condenser keeps the points from sparking. In a battery system, you can tell by looking at the breaker points whether a condenser is of the proper size. If the points are greatly pitted, the condenser may need to be replaced.

HOW THE COIL WORKS

To increase the voltage of the battery electrical system, a coil is used. In the center of the coil is a soft iron core. Over the core are wrapped a few turns of heavy wire, called the primary. As current flows through the primary winding, it is interrupted by a set of breaker points. A condenser made of two strips of metal separated by a thin piece of paper and wound in a small roll is connected across these points. As the breaker points interrupt the current, it surges quickly into the condenser and then out again. The condenser keeps the points from arcing and burning. The condenser is also used to make a current of higher voltage flow in the secondary winding.

The secondary winding consists of many thousand turns of fine wire. As the current is induced into these many turns of fine wire, its voltage is increased to more than 20,000 volts. Because of the high voltage the current will now jump the gap at the spark plug.

You might compare voltage to the pressure needed to shoot a stream of water across a yard—the farther you wish to shoot the water the more pressure you need. In an electrical system we call this pressure high voltage. It is this high voltage that can give you a shock if you're not careful.

DISTRIBUTOR

After producing a high-voltage current just as the breaker points open, the next thing the ignition system must do is carry the current to each spark plug in turn at the proper time. A distributor is used to do this. The distributor is a rotating switch driven by the engine through gears. It usually rotates at one-half engine speed. Each time the sparking current is produced, the switch connects to a different terminal. By running heavy ignition wires from the proper terminal to the proper spark plug, each plug fires at the right time. The heavy insulation is needed so that the spark will not jump from the wire.

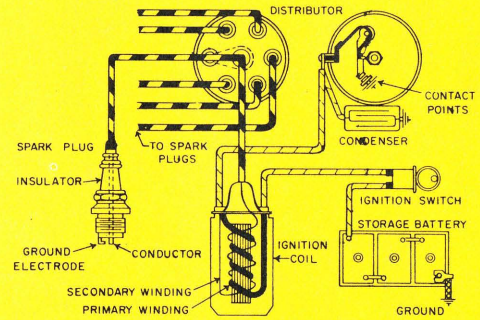

Fig. 5. Battery ignition system for carburetor engines.

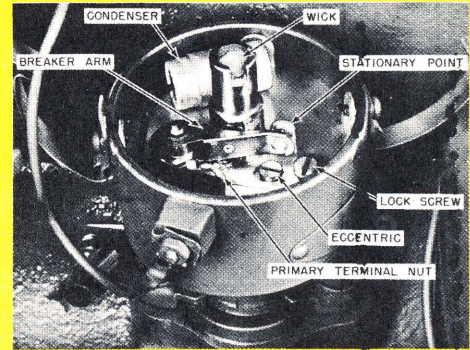

Fig. 6 Distributor with cap removed.

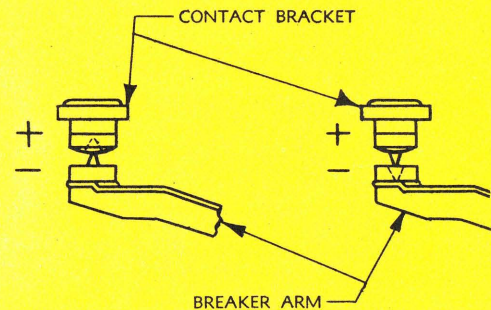

Fig. 7 Badly pitted points caused by shorted or over-capacity condenser (left) or under-capacity condenser (right).

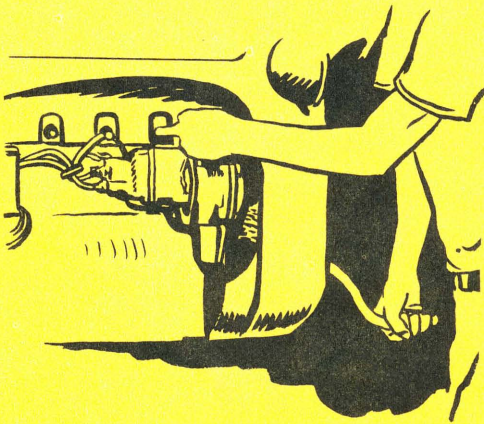

Fig. 8 Checking compression at No. 1 piston.

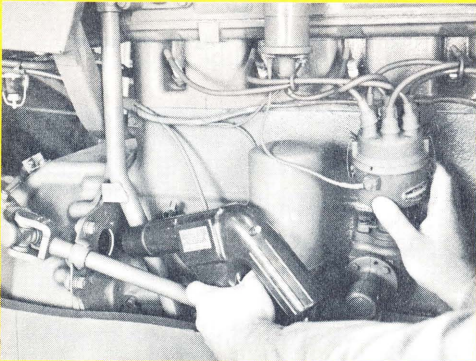

Fig. 9 Using a timing light.



Fig. 10 Checking direction in which rotor turns.

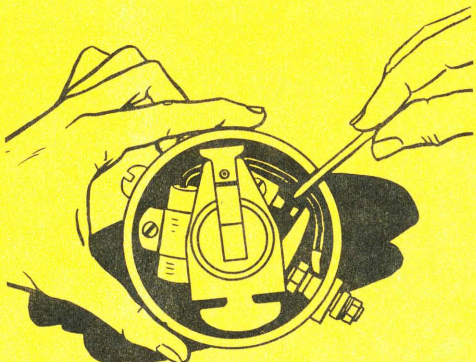

Fig. 11 Rotating the distributor case to time a battery ignition engine.

TIMING

Showing how to time an engine makes a good demonstration. Your Operator's Manual tells you how to do this job.

There are two steps in timing an engine. First, rotate the crankshaft until the engine is completing the compression stroke for the No. 1 cylinder. The No. 1 cylinder is the one nearest the crank. On four- and six-cylinder engines, this takes place when the back exhaust valve (the one closest to the flywheel) closes. Just as this valve closes, the No. 4 cylinder has completed its exhaust stroke and No. 1 cylinder has completed the compression stroke. Another way to check the compression stroke is to remove the No. 1 spark plug. Place your thumb over the hole and turn the engine until you feel pressure. Then turn slowly until the timing marks are lined up.

After the engine is in proper position for firing cylinder No. 1, the second step is to set the ignition system so that it has just produced a spark. Then connect the ignition system to the engine.

TIMING A BATTERY IGNITION SYSTEM

Turn the engine over to the point where you want a spark. Then rotate the distributor case carrying the points until a spark is produced. A spark is always produced just as the breaker points separate.

Some engines are timed with the spark advanced. A timing light is usually used where you want to time with advanced spark. Ask your dealer or leader to show you how to use a timing light. To time the engine, hook the light to the No. 1 or No. 4 spark plug wire, or on a six-cylinder engine to the No. 1 or No. 6 wire. Run the engine and note if the light goes on just as the timing mark on the flywheel or fan pulley is lined up with the pointer.

If you do not have a timing light, you can time the engine by turning it until the spark advance mark is lined up with the pointer. Then advance the distributor rotor by turning it in the direction of rotation and holding it in the advanced position. This advances the cam, which opens the points. Turn on the switch and rotate the distributor case in the opposite direction until a spark occurs. Better have your leader or dad show you how to do this.

You can tell the direction of rotation of the rotor on most tractors by turning it with your fingers. With the engine stopped, you can turn the rotor a short distance in the direction of rotation. The reason you can turn it is because you are throwing the spark advance weights out against the spring.

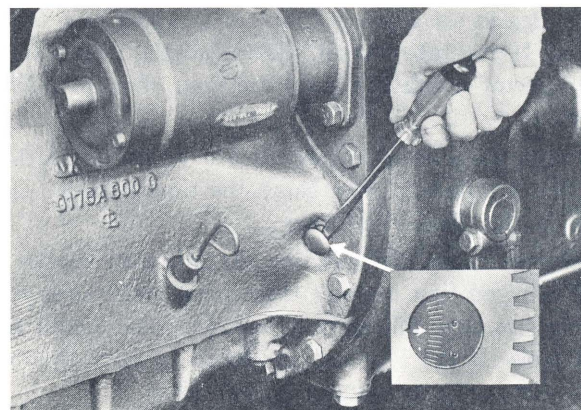

Fig. 12 Removing flywheel timing hole plug.



AUTOMATIC SPARK ADVANCE

The spark advance for the battery ignition system is more flexible than that for a magneto. With a magneto, you retard the spark for starting and after the engine reaches a speed of about 450 rpm or more, you have full spark advance. In a battery system the spark is retarded by springs pulling against weights. When starting, the springs keep the weights pulled in and the spark is retarded. As the engine picks up speed the weights pull out and gradually advance the spark. Any change in engine speed also causes a change in the spark advance. The result is better idling and somewhat better load-pulling ability at low speed.

CHECKING BREAKER POINTS

The breaker point gap should be checked periodically. Your Operator's Manual will tell you how often to make this check. It will also give the proper spacing.

Always use a flat feeler gauge to check the spacing. Be sure the engine has been turned until the points are wide open. The proper gap is provided when there is a slight drag on the feeler gauge as you pull it between the contact points.

If the points are set too close they will burn and pit rapidly. If the points are set too wide they may cause a weak spark at the higher engine speeds. Be sure the breaker points fit together squarely. If they make only partial contact, there will be burning, pitting, and uneven wear. You may have to bend the points into position to get them to fit squarely. Be careful! Ask Dad to help if you are not sure.

When you finish working with the breaker points, run a strip of clean paper between the contact surfaces to remove any grease or dirt particles. Grease or dirt on the points will cause burning and pitting.

TIMING A DIESEL ENGINE

A diesel engine does not need a special ignition system. It depends on the heat of the highly compressed air to start the fuel burning. The fuel pump must be timed so as to inject fuel at the proper time. Timing a fuel pump varies on different engines. Therefore, if you have a diesel it will be necessary for you to refer to your Operator's Manual to determine how it should be timed. Better have an older, experienced person help you with this job.

It is important when working with a diesel engine to **KEEP ALL PARTS CLEAN**. Before disassembling any fuel lines, be sure to clean off the dirt. It is also a good idea to use a piece of tape or a cap to close off the line while it is disconnected. If you take out an injector nozzle, handle it carefully. The spray from an injector nozzle can puncture your skin, so **NEVER** point an injector at anyone.

To check the timing on a diesel engine, turn it until it is on the compression stroke for the No. 1 cylinder. Then check the timing marks on the pump to see if they are in the proper position.

Timing the injection pump and cleaning the injection nozzles are jobs that require skill. When you first attempt these jobs, make sure you have someone help you who has done this work before. On some diesels these jobs may require special tools. If the jobs are not listed in your Operator's Manual, have this work done at your tractor dealer's shop.

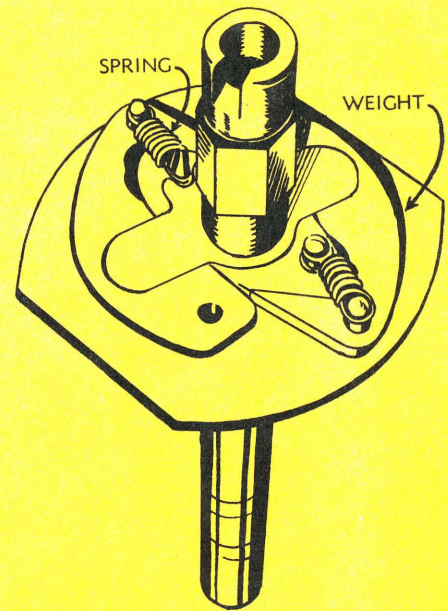

Fig. 13 Automatic spark advance in distributor of battery system.

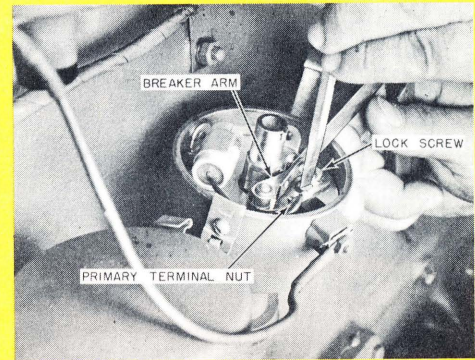

Fig. 14 Adjusting breaker point gap with flat feeler gauge.

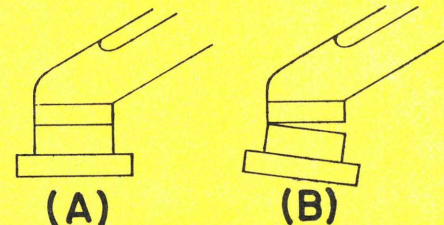

Fig. 15 (A) proper alignment of breaker points. (B) improper alignment causes burning and pitting.

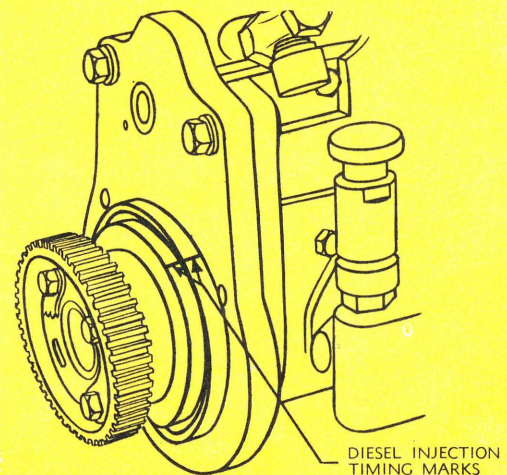

Fig. 16 Timing marks on the fuel pump of a diesel.

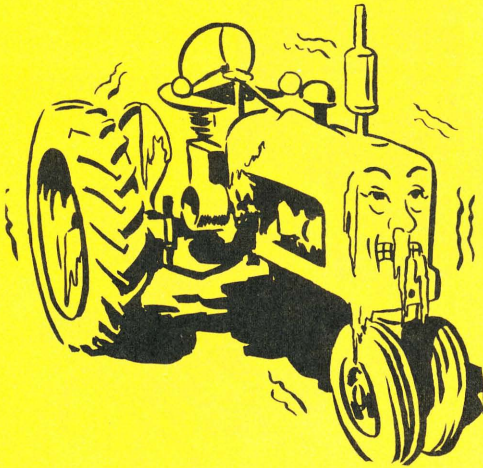
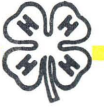

Fig. 17 Starting in cold weather takes more power.

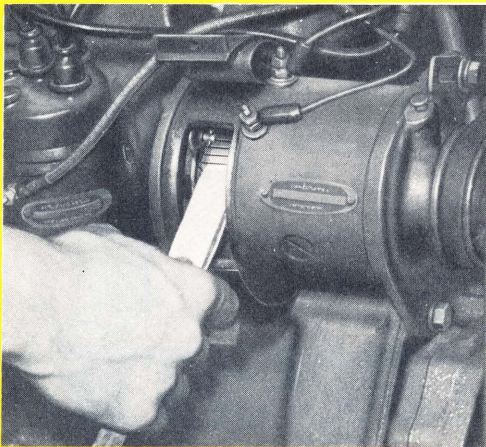

Fig. 18 Clean and smooth the commutator of your generator with sandpaper.

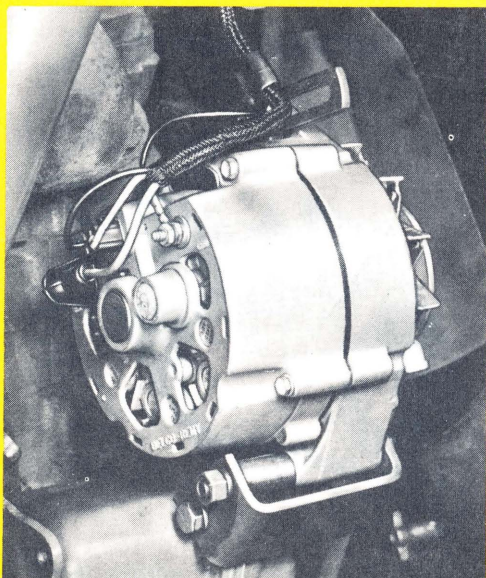

Fig. 19 Alternators maintain a high charging current at all engine speeds.

WINTER BATTERY CARE

One disadvantage of the battery ignition system is that when you try to start the engine in cold weather, the cold battery will not deliver full power. Much of that power is taken by the electric starter. This condition leaves less current for the ignition system and the result is a weak spark. You can easily see why you want to keep the battery well charged in the winter. Releasing the clutch when starting in cold weather will reduce drag from the transmission. Keeping the tractor in a warm shed will aid in starting it in cold weather.

COMPARISON OF CRANKING POWER AVAILABLE FROM A FULLY CHARGED BATTERY AT THREE DIFFERENT TEMPERATURES:

80°F.	—	100%
32°F.	—	65%
0°F.	—	40%

GENERATOR SERVICE

A generator is used for charging the battery. If the generator commutator becomes dirty or slightly grooved, it can be cleaned and smoothed by placing a piece of No. 00 sandpaper on it while the generator is turned slowly by the engine. Be sure to blow out all the dust. Never use emery paper for cleaning the commutator because emery dust could cause a short circuit. Oil the generator bearings only slightly, as recommended.

If you run magneto-equipped engines without the battery, always make sure to remove the generator belt or the field wire (the one connected to terminal "F"). Removing and taping the field wire will keep the generator from burning out. Watch for loose connections. They can cause the generator to burn out, too.

ALTERNATORS

On many of the newer tractors an alternator is used in place of a generator. They are called alternators because an alternating current is produced. A rectifier is then used to change the alternating current to direct current for charging the battery. An alternator has the advantage of maintaining a high charging current at all engine speeds, even when the engine is idling. If your tractor is equipped with an alternator you need to be careful not to cause a short across the terminals as the alternator can be seriously damaged. Do not attempt to polarize the alternator, operate it as a motor, or run it with an open circuit. If you must use a booster battery or a battery charger be sure to connect the negative lead to the negative terminal and the positive lead to the positive terminal. Otherwise, the alternator will be shorted, causing extensive damage.

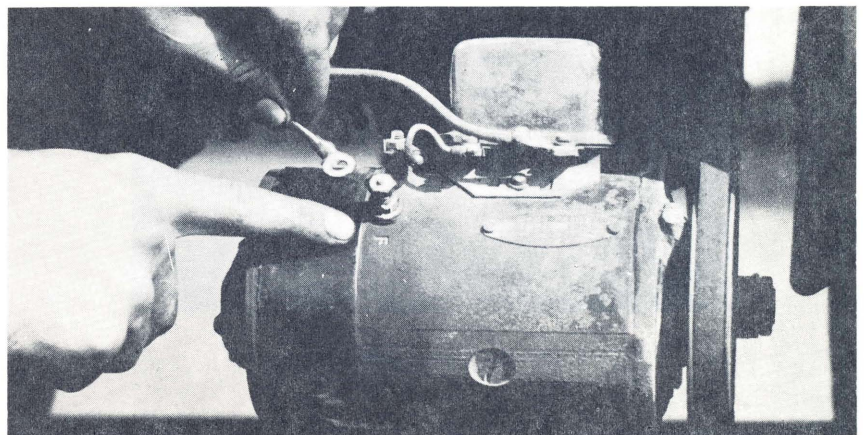

Fig. 20 If the engine has a magneto be sure to remove the field wire (terminal "F") before running engine without a battery.



VOLTAGE REGULATOR

Many newer engines are equipped with a voltage regulator, which varies the rate of generator charge automatically. The condition of the battery determines how much current the generator puts out. When the battery is used very little, the generator charges very little.

Do not tamper with the voltage regulator. If it does not appear to be in working order, if the battery will not stay charged under normal conditions, or if the ammeter shows a high charge rate, see a serviceman. A continuously high charging rate may indicate that the voltage of the battery is low. A shorted cell will cause the charging rate to stay high; if this is the cause, you need a new battery.

Generators are equipped with an automatic switch called a cutout. The cutout disconnects the generator from the battery whenever the engine is running too slow to charge or is stopped. The cutout seldom needs attention except for an occasional cleaning and polishing of its points with No. 00 sandpaper.

GENERATOR DEMONSTRATION

A simple test shows whether the generator is working or has been burned out. Disconnect the belt on the generator and hold the contact points of the cutout closed. If the generator runs slowly (with the engine shut off) like an electric motor, it is in working order. The ammeter should not show a discharge over 2 to 4 "amps" when this test is made.

THE STARTER

If you lubricate the starter according to instructions in your Operator's Manual and keep the electric terminals clean and tightly connected, you will seldom have starter trouble. If the commutator becomes dirty, clean it with No. 00 sandpaper in the same manner recommended for the generator commutator.

Do not overheat a starter. If your engine does not start readily, find out what's wrong with it by "trouble shooting." Do not press the starter button more than 15 seconds at a time.

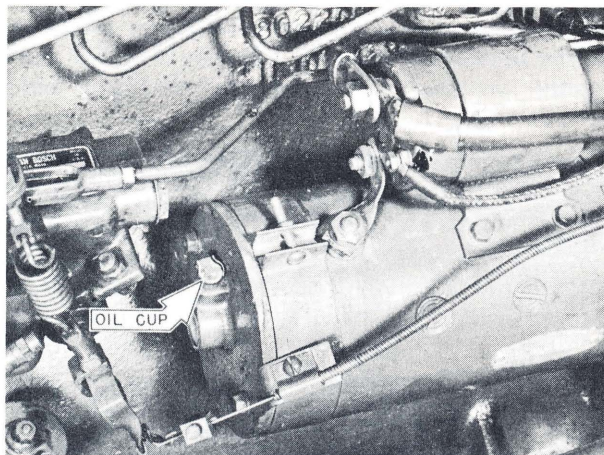
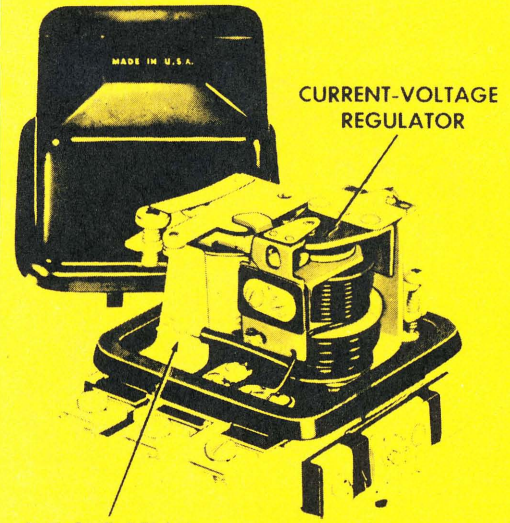

Fig. 24 Oil cup on starting motor.



CUT-OUT RELAY

Fig. 21 A voltage regulator.

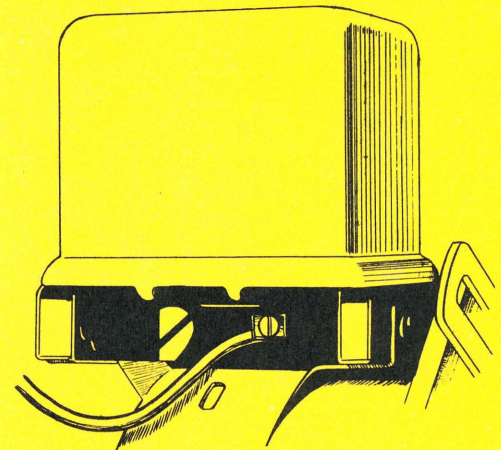

Fig. 22 A generator cutout.

LET'S DEMONSTRATE

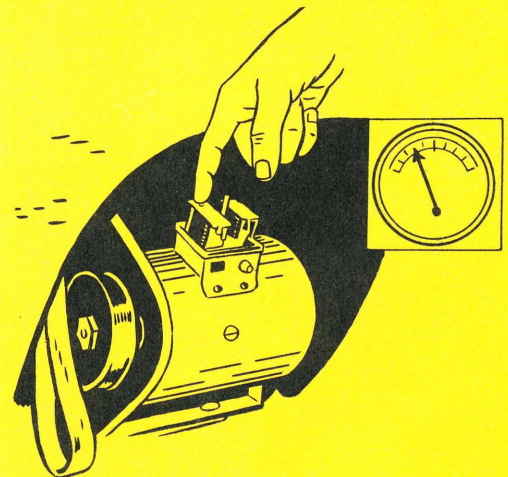

Fig. 23 You can show whether the generator works by disconnecting the belt and holding the cutout closed. Inset shows ammeter reading 2 to 4 amps.



Answer these questions and do the jobs listed. If you have a diesel engine, answer all the questions which apply to your engine. List on the back of this page the steps necessary to check the timing. Tell how to clean the injector nozzles and how you start your diesel engine during cold weather.

1. What is the make, model, and year of your tractor? _____
2. Where is the timing mark on your tractor? _____
3. Is the timing mark for advanced or retarded timing? _____
4. What cylinder do you use for checking the timing? _____
5. Why are breaker points used in an ignition system? _____
6. Does your ignition system have a condenser? _____
7. Why is a condenser used? _____
8. What is the firing order of your engine? _____
9. Is the spark automatically retarded and advanced on your engine? _____
10. How is this done? _____
11. What is the correct breaker point gap? _____
12. Do the points appear to be in good condition? _____
13. How do you check the timing of your engine? _____

14. Clean the commutator on a generator. See that the brushes work freely in their holders. Oil the generator bearings. What would you do if you needed to operate a magneto engine some day without a battery? _____
15. Check a generator. Did it run when you closed the cutout switch with the belt removed? _____
How can you adjust the rate of charge on your generator? _____

16. Does the starter on your engine have any lubricating fittings? _____
17. How did you clean the commutator? _____
18. List on the back of the page other important points you have learned about ignition systems.

Note: Fill out this work unit, using your own tractor at home. Be ready to discuss your experiences with other 4-H members at your next club meeting.



THIRD YEAR UNIT 2

ENGINE IGNITION SYSTEMS

Place the letter for the correct answer at the right of the page.

1. A diesel engine: (A—has a special spark ignition system) (B—depends on high compression and heat for ignition) (C—runs best when cold). _____
2. A magneto: (A—generates its own electric current) (B—takes electricity from the air and needs no battery) (C—stores electricity in the magnets). _____
3. A coil: (A—increases the power of a battery) (B—steps up the voltage for the spark plug) (C—reduces the voltage so the spark will jump the plug gap). _____
4. A condenser is used in the ignition system to (A—prevent arcing across the breaker points) (B—change the current from direct current to alternating current). _____
5. If the breaker point gap is (A—too wide) (B—too narrow) the engine may miss at high speeds. _____
6. Ignition must be advanced on a gasoline engine when running: (A—to allow full firing of the fuel charge by the time the piston starts down) (B—to allow time for a hot spark to build up) (C—to keep engine from kicking). _____
7. On modern tractors the charging rate of the generator is controlled by (A—the automatic spark advance) (B—the voltage regulator) (C—a hand switch). _____
8. Diesel engines (A—do) (B—do not) have to be timed. _____
9. If you disconnect the belt on a generator that is in good condition and hold the contact points of the generator closed: (A—it will turn slowly—as a slow-running motor) (B—sparks will fly) (C—nothing will happen). _____
10. The best water for batteries is: (A—rainwater) (B—water from deep wells) (C—salt water). _____

Note: This Check-Up Sheet is intended to test what you have learned and to stimulate discussion with the other members. The more you discuss these questions with your leader and the other members the more you learn.

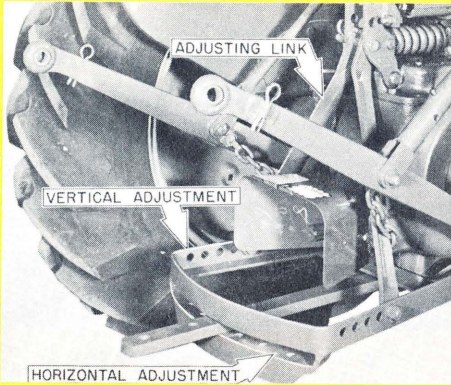

Fig. 1 A swinging drawbar.

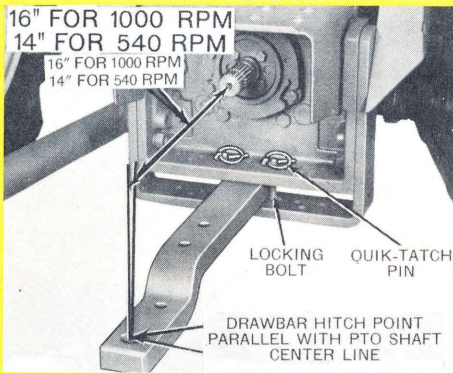

Fig. 2 Be sure the drawbar is in the proper position when using the PTO.

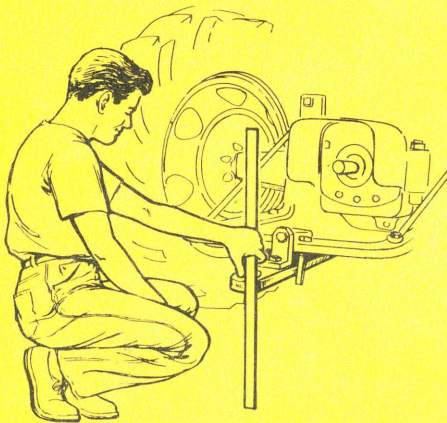

Fig. 3 Check the height of your drawbar.

Have you ever thought about the many different ways in which your tractor can be used? Some tools, such as a drag harrow, are merely hitched to the drawbar. If you have a wheel disk you might also use a remote-controlled hydraulic cylinder. Still other implements, such as a forage chopper, may be driven by the PTO (power-take-off) shaft from the tractor, with a hydraulic cylinder being used for adjusting the height of the feeding unit. You should know how to connect implements correctly, and how to operate the equipment safely.

CHECK THE DRAWBAR HEIGHT

When you hitch your tractor to an implement, it is important always to use the drawbar. Do not try to pull a load from the axle or seat, or from one of the links of a three-point hitch. When you do, there is danger of upsetting your tractor or damaging it mechanically.

Check the height of the hitch on your tractor. The distance should be from 13 to 17 inches as measured between ground level and the hitch point on the drawbar. Adjusting your drawbar to this height not only provides safer hitching but is also standard height for use of the PTO shaft.

CAUTION: When using a tractor that is equipped with a hydraulically controlled drawbar to pull a load, use the stay bars provided with your tractor to lock the hitch in position. Raising the hitch to increase traction is a dangerous practice that can cause a backward upset.

HITCHES FOR PTO OPERATION

The drawbar on most tractors can be adjusted for either a close hitch or an extended hitch. You will need to use the extended hitch for connecting to a machine that is driven by the PTO shaft. There are two standard speeds for the PTO shaft on newer tractors. One is 540 rpm, the other is 1,000. If you use a PTO speed of 540 rpm, the hitch point must be 14 inches from the end of the PTO shaft. If you use a PTO speed of 1,000 rpm, the distance from the hitch point to the end of the PTO shaft must be 16 inches. Trying to use a drawbar connection that is too short will cause the universal joints on the PTO shaft to bind when you make a short turn.

If your tractor hitch can't be adjusted to the proper distance, check with your dealer. He should have a drawbar extension which will provide the proper length.

When using the PTO shaft, be sure the drawbar is centered directly under the shaft and securely fastened.

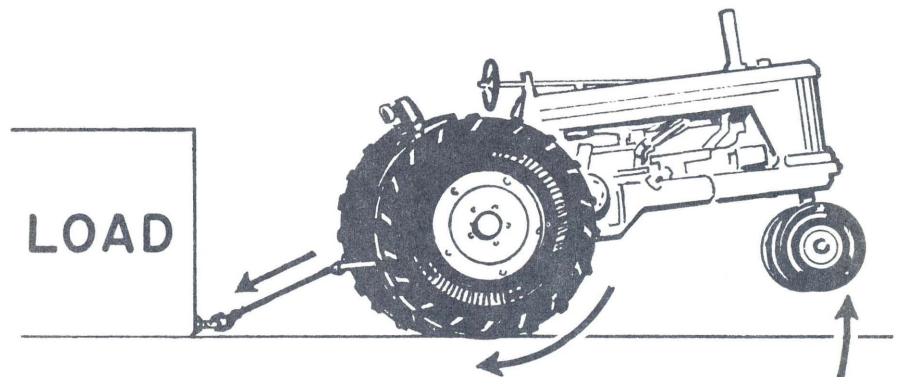

Fig. 4 The load tries to raise the front end of the tractor.



HITCHES FOR MOUNTED EQUIPMENT

Most modern tractors are equipped with hydraulic controls for raising, lowering, and adjusting rear-mounted equipment. This is why more rear-mounted equipment is used than in the past. Previously, equipment was raised and lowered with long hand-levers and this became quite tiresome.

Rear-mounted equipment is connected to the tractor with "integral hitches." Integral hitches may have one-, two-, or three-point connections between the rear-mounted implement and the tractor. Of these three types, the three-point hitch is the most common.

Three-point hitches are standardized so that implements and tractors of different makes and models can be used interchangeably. If your tractor does not have a three-point hitch you can probably get an adapter that will let you use three-point mounted equipment.

The sizes of three-point hitches are standardized by categories. Small tractors use a Category I hitch and larger tractors use a Category II hitch. Figs. 7 and 8 show the measurements of these two hitches. As tractors and implements continue to increase in size, additional categories will be added. By using special adapters, Category I equipment can be used on tractors with Category II hitches.

THREE-POINT HITCH ADJUSTMENTS

When a rear-mounted implement is connected to a tractor, the main adjustments are provided by the three-point linkage. On a plow, for example, the length of the top link can be adjusted to provide the proper pitch or depth control. If you wanted the plow to go deeper you would shorten the top link. If you wanted the plow to run shallower you would lengthen the top link.

Adjustments are also provided for leveling the rear-mounted implements. This is usually done by a hand crank on the linkage that controls the height of the right-hand (as viewed from the rear of the tractor) draft link. On some tractors both of the draft links can be controlled with a leveling crank.

The raising and lowering of the entire three-point hitching system is powered by the hydraulic system. There is a hand lever on the tractor that lets you raise and lower the implements and adjust it to run at a given depth.

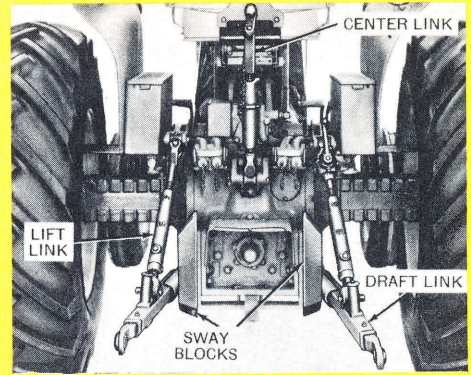

Fig. 5 Rear-mounted hitch on a wheel tractor.

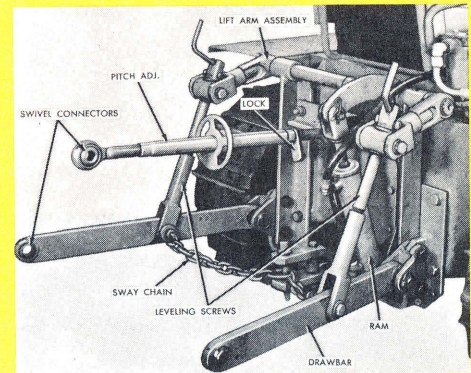

Fig. 6 Rear-mounted hitch on a crawler tractor.

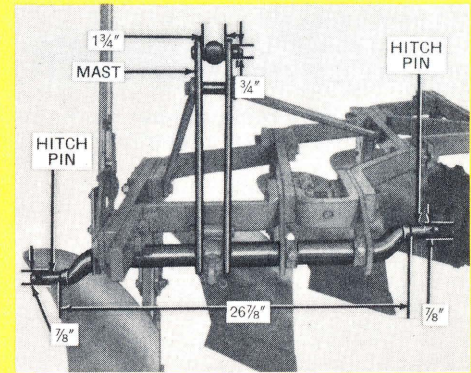

Fig. 7 Dimensions for Category I hitch.

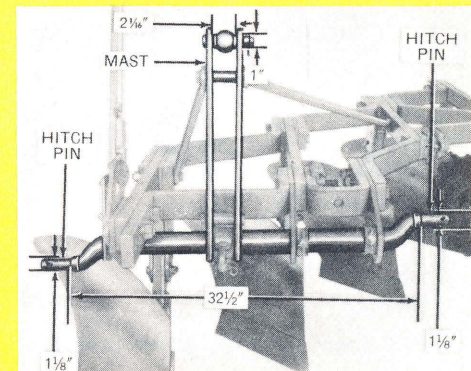

Fig. 8 Dimensions for Category II hitch.

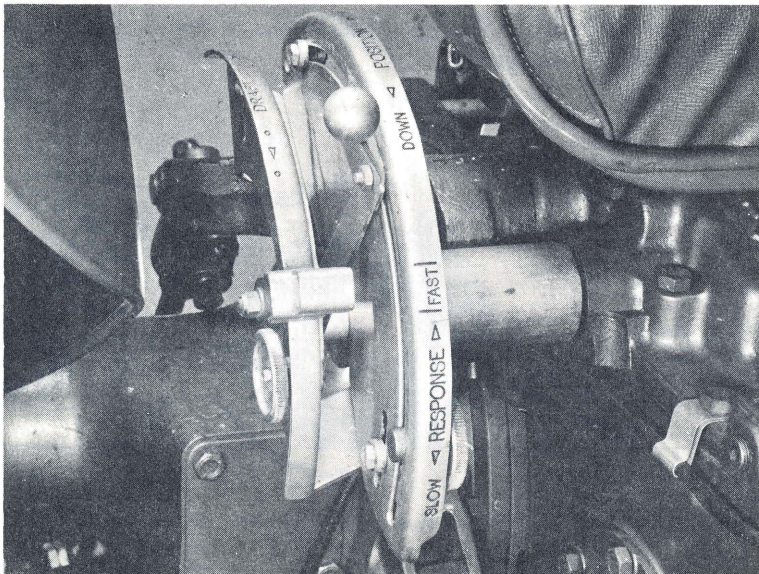

Fig. 9 Levers for raising and lowering a three-point hitch.

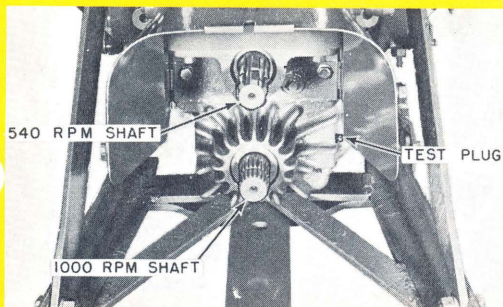

Fig. 10 Two PTO shafts on a tractor.

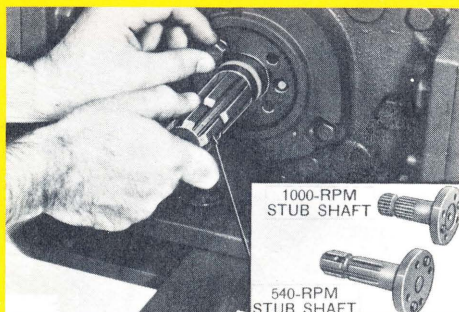

Fig. 11 Changing the stub shaft to change the PTO speed.

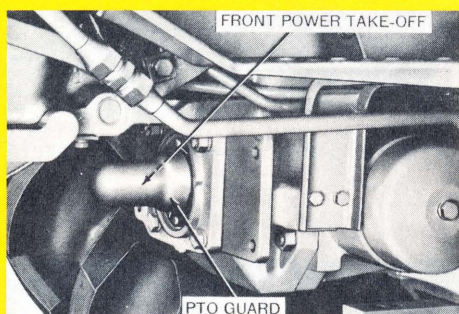

Fig. 12 1,000 rpm auxiliary power shaft.

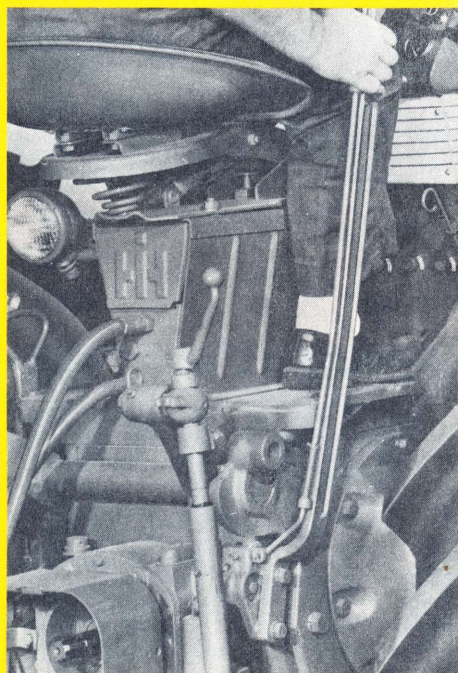

Fig. 13 Separate clutch for PTO.

TWO STANDARD PTO SPEEDS

As mentioned earlier, there are two standard speeds for the PTO shaft. The old standard of 540 rpm was used on all tractors until 1958. At that time a new standard speed of 1,000 rpm was accepted. The new standard speed was needed in order to increase the amount of power and speed that could be transmitted to a machine.

It will probably take several years for the new speed to come into general use. During the change-over period many of the new tractors are providing for both standard speeds. This is done by making the PTO so that it can be operated at either 540 or 1,000 rpm by adjusting a pin or a lever. The stub shaft for 540 rpm has a 6-tooth spline, while the stub shaft for 1,000 rpm has 21 teeth. Because the stub shafts have different kinds of splines you can't accidentally operate a machine at the wrong speed.

AUXILIARY POWER SHAFT

Some mounted equipment must be driven by the PTO but cannot be easily connected to the rear PTO shaft. Therefore, some of the newer tractors have a front or side power shaft that rotates at 1,000 rpm. It may be a separate stub shaft, or the stub shaft for the rear PTO may be used.

PTO CLUTCH

For many years the PTO was driven from the transmission and was controlled by the engine clutch. If you were pulling a machine such as a combine and the combine started to overload, there was no way to stop the forward motion and let the combine continue to run to clear itself.

With the transmission-driven PTO, when you stopped the tractor movement you also stopped power to the machine. If you wanted the machine to continue to operate you had to shift into neutral and re-engage the clutch.

To overcome this disadvantage the independent or continuous running PTO was developed. In this case the PTO is controlled by a separate clutch that can be used whether the tractor is in motion or standing still.

USE PTO SHIELDS

Any rotating shaft that is not covered by a guard can be dangerous. Even a smooth shaft will grab clothing and cause it to start wrapping should you brush against it. Once caught, you are no match for the speed and power of a PTO shaft. Keep the shields in place at all times. Use the standard shields provided with your tractor and equipment. Keep the stub shafts covered when they are not being used. They could be unintentionally engaged and cause an accident.

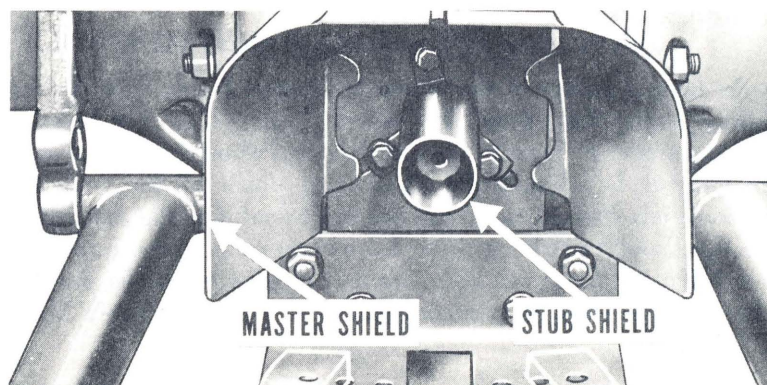

Fig. 14 Keep shields in place.



HYDRAULIC SYSTEMS

The hydraulic system on your tractor provides a quick and easy means for attaching and lifting various implements and controlling their adjustment. There are many different kinds of hydraulic systems. Some have their own oil supply while others may be part of a central system that is also used for power steering or power brakes. In some models the transmission and hydraulic system use the same oil.

To know how to use the hydraulic system on your tractor study your Operator's Manual carefully. It will tell you where all of the adjustments and controls are located and how to use them. Once you become familiar with the hydraulic system on your tractor you will find there is almost no limit to the different ways it can be used.

REAR-MOUNTED EQUIPMENT

The hydraulic system controls the raising, lowering, and adjustment of the linkage for rear-mounted equipment. You may find that your tractor has a control for running mounted equipment at a constant depth regardless of the amount of pull required. Or you can adjust the control so that the load remains the same and the depth will vary slightly. How you adjust this control will depend on the equipment you are using and the conditions under which it operates.

REMOTE CYLINDERS

Single-acting cylinders are connected to the hydraulic system by only one hose and can exert force in only one direction. They are usually used on equipment where a simple raising and lowering action is needed. In such cases they are located so that the load returns the cylinder to its home position. Double-acting cylinders have two hoses and can exert force on an implement in both directions. Double-acting cylinders are commonly used on equipment where it is necessary to adjust a machine to a given position. These cylinders are standardized so that they can be used on various combinations of tractors and equipment.

When used on a tool such as a plow, double-acting cylinders may contain a device that controls the length of the stroke. With this control you can select the length of stroke needed to operate the equipment at the desired depth.

SERVICING THE HYDRAULIC SYSTEM

Dirt is the biggest enemy of the hydraulic system. It can ruin the seals and close-fitting parts that keep the system under high pressure. Always maintain the proper oil level in the reservoir and change the oil at the recommended interval. It is important to use the proper oil for your hydraulic system. Some oils contain additives that are harmful to the seals. Be careful with the hoses and hose connections. Keep them clean and use the dust seals provided when the hoses are disconnected. If your hydraulic system has a filter, be sure you clean it as recommended in your Operator's Manual.

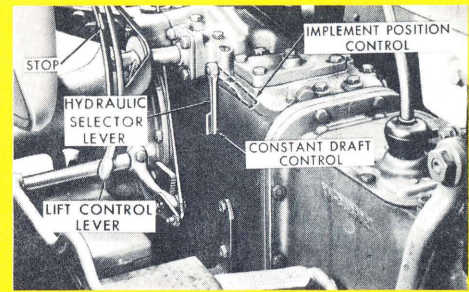

Fig. 15 Hydraulic controls for rear-mounted implement.

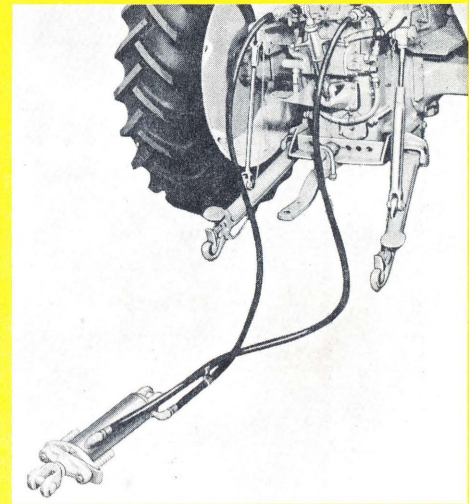

Fig. 16 Double-acting remote cylinder.

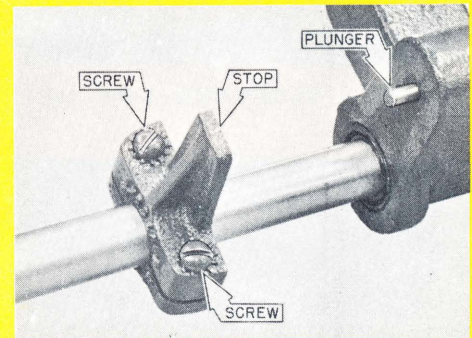

Fig. 17 Adjustable stop for controlling depth.

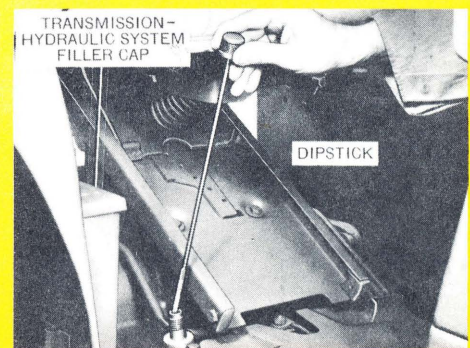

Fig. 18 Checking the oil level in transmission-hydraulic system.



1. Check the drawbar on your tractor. What is the height of the hitch point? _____ inches.
Can the height be adjusted? _____

2. Does your tractor have a swinging drawbar? _____ Where should it be located when hitched to a machine that is driven by the PTO shaft? _____

3. Which machines on your farm need to be connected to a swinging drawbar when it is allowed to swing freely? _____

4. Does your tractor have a rear-mounted hitch? _____ How many adjustments and controls does it have? _____ What are they? _____

5. Can the PTO shaft be operated at either 540 or 1,000 rpm? _____
How is it changed from one speed to the other? _____

6. Is the PTO shaft driven from the transmission or does it have a separate clutch? _____
Can the PTO clutch be adjusted? _____ How? _____

7. What kinds of PTO shields are provided for your tractor? _____

8. Does your tractor have a hydraulic system? _____ Is it a separate system or is it combined with some other system on your tractor? _____
Explain _____

9. How many remote cylinders can be used with your tractor? _____

10. Can your tractor use both single- and double-acting cylinders? _____

If so, how is this done? _____

11. What precautions do you take to keep dirt out of the hydraulic system? _____

12. Make a list of the safety precautions you should take for each of the following:

a. Hitching to the drawbar, or attaching rear-mounted equipment. _____

b. Connecting and using the PTO shaft. _____

c. Connecting and using hydraulic controls. _____

Note: Fill out this work unit, using your own tractor at home. Be ready to discuss your experiences with other 4-H members at your next club meeting.



THIRD YEAR UNIT 3

HITCHES, PTO, AND HYDRAULIC CONTROLS

Place the letter for the correct answer at the right of the page.

1. Raising the drawbar height (A—increases) (B—decreases) the chance of a backward _____
upset.
2. The proper horizontal distance between the end of the PTO shaft and the hitch point _____
on the drawbar for operating the PTO at 1,000 rpm is (A—14 inches) (B—16 inches).
3. The spline for a 540 rpm PTO shaft (A—is) (B—is not) the same as the spline for a _____
1,000 rpm shaft.
4. Three-point hitches (A—are not) (B—are) standardized. _____
5. Single-acting hydraulic cylinders (A—exert force in one direction only) (B—exert force _____
in both directions).
6. Auxiliary power shafts all run at (A—540 rpm) (B—1,000 rpm) (C—no certain _____
speed).
7. When an implement is operated with the PTO shaft in use, the drawbar should be in _____
the (A—close) (B—extended) position.
8. Category II mounted equipment (A—can) (B—cannot) be used on a tractor with a _____
Category I rear-mounted hitch.
9. Shortening the top link of a three-point hitch will make a plow run (A—deeper) (B— _____
shallower).
10. It (A—is) (B—is not) always safe to use regular crankcase oil in the hydraulic system. _____

Note: This Check-Up Sheet is intended to test what you have learned and to stimulate discussion with the other members. The more you discuss these questions with your leader and the other members the more you learn.

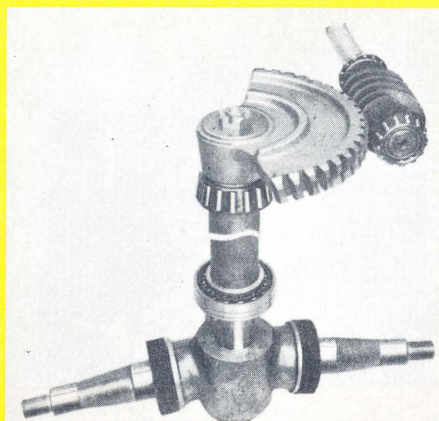

Fig. 1 Tractor steering mechanism. Note sector and worm gear.

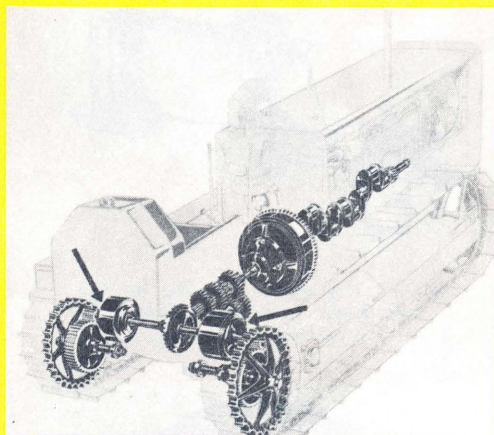

Fig. 2 Steering a crawler tractor —arrows show steering clutches.

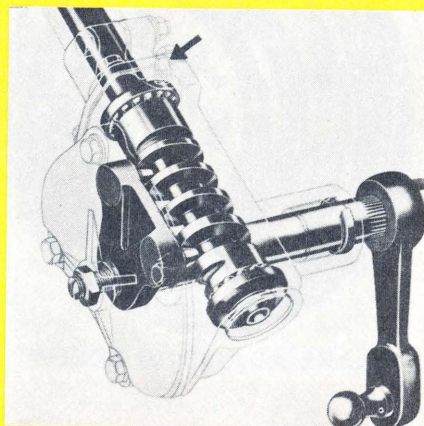

Fig. 3 Steering gear and its oil-tight case.

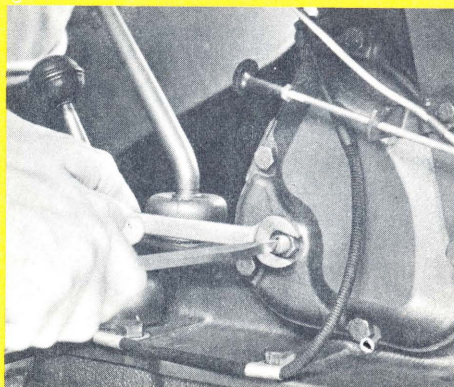

Fig. 4 Adjusting backlash in steering gear.

To make it possible for a small force to turn the front wheels of a tractor, the steering mechanism is built with a set of gears having a high ratio. A worm gear is usually used on the end of the steering wheel shaft. The worm usually turns only part of a gear, called a "sector."

STEERING TRACK-TYPE TRACTORS

If you have a track-type tractor, you steer it by slowing down or stopping one of the tracks. You do so with a brake or clutch. Members who have a track-type tractor will use their Operator's Manual for learning about steering, track adjustment, and track roller lubrication.

Anti-friction (ball or roller) bearings hold the gears in alignment. Both the gears and bearings are usually enclosed in an oil-tight case which contains the lubricant for the gears and bearings. On some steering gears, some of the bearings and shafts must be lubricated by a grease-gun fitting.

STEERING GEAR ADJUSTMENT

Steering-gear bearings and gears are adjustable. After the tractor has been in service for some time, these parts should be checked for wear and adjusted if necessary. The Operator's Manual usually tells how to adjust the steering gear. If this information is not in the Manual, take the tractor to the dealer for adjustment or obtain instructions from him.

STEERING GEAR LUBRICATION

Check the steering-gear case frequently to make sure that it has the right amount of lubricant. A loosened cap screw or a faulty seal may cause the lubricant to leak. The lubricant in the gear case is usually at the correct height when it covers about half the gear.

At least once a year the case should be drained and refilled with new lubricant. Straight gear lubricant of the same type used in the transmission is usually recommended but when leakage causes trouble, pressure-gun grease is sometimes used.

CHECKING FOR LOOSENESS

When the gear case cover is removed for inspection, check the large nut at the top of the vertical shaft for looseness. A loose nut here, on some tractors, can cause excess play in the steering gear.

By jacking up the front end of the tractor and using a long bar under the front axle, the vertical steering shaft of cultivating tractors can be checked for end-play.

The steering arms, ball-and-socket connections, universal joints, and other parts should be inspected and loose parts adjusted or replaced.

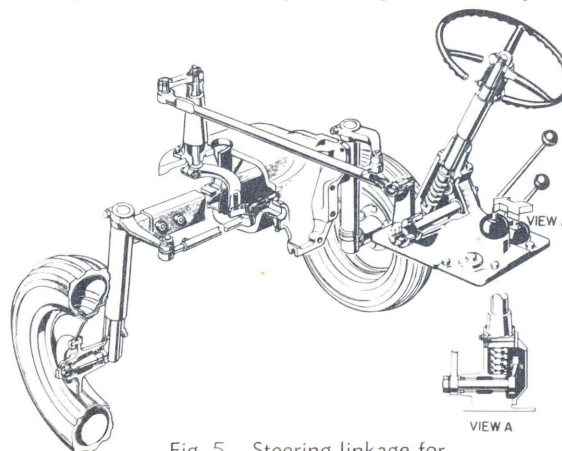

Fig. 5 Steering linkage for a four-wheel tractor.



POWER STEERING

Many tractors have a power steering system that attaches to the standard manual steering and uses oil under pressure to help turn the front wheels. Oil under pressure is also used on some tractors to provide all of the power for steering and there are no mechanical connections to the front wheels.

With power steering, if the engine isn't running, no power is available to assist in turning, but the tractor can be guided manually. When the engine is running, power is available for steering whenever the force applied at the steering wheel is greater than about 4 to 11 pounds. This provision gives you the "feel" of manual steering yet relieves you of the extra strain of hard steering.

There are many kinds of power steering. Some kinds use their own oil supply and pump. Others are connected to a central oil system that may also supply oil to the hydraulic system.

When operating a tractor with power steering, do not hold pressure with the steering wheel cramped in an extreme position. This could over-load the pump and by-pass valves, causing damage to the system.

Whether the power steering has its own oil supply or is part of the main hydraulic system, it should be treated as any other lubricating system. Keep a constant check on the oil level and change the oil at the recommended intervals.

ADJUSTING THE BRAKES

Brakes can be used individually to help make a short turn at slow speeds. Both brakes should be used at the same time to stop the tractor quickly in an emergency. In this situation, uneven brake adjustment may easily cause a tractor to lurch sideways and upset. This is why it is important to keep brakes adjusted evenly.

Several kinds of brakes are used on tractors, but they can all be classified as mechanical or hydraulic. Mechanical brakes include a band-type, a shoe-type similar to that used on automobiles, and a disc-type that works much like a clutch. Hydraulic brakes obtain their power from the hydraulic system to operate discs that run in oil. Very little pressure is needed on the foot pedals to operate hydraulic brakes. They also require no adjustment except to bleed air from the hydraulic system. Air in the hydraulic system causes brakes to fade when applied. They will feel spongy when the engine is not running.

Recommended intervals for adjusting brakes vary from 200 to 400 hours. Check your Operator's Manual for instructions on adjusting the brakes on your tractor.



Fig. 6 A tractor that has its own power steering oil supply.

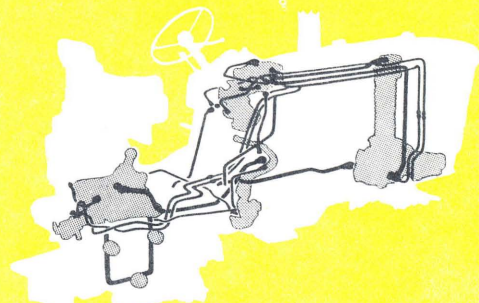

Fig. 7 The power steering on this tractor gets its oil supply from a central hydraulic system.

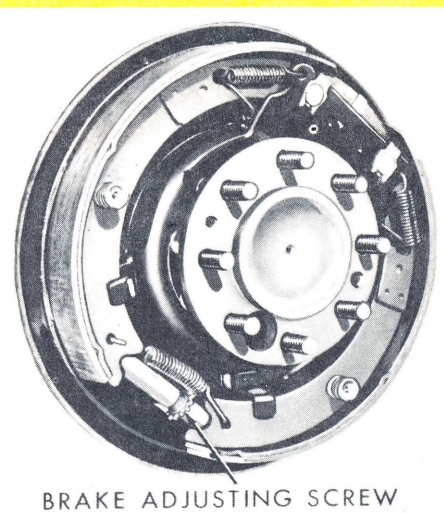

Fig. 8 A shoe-type brake.

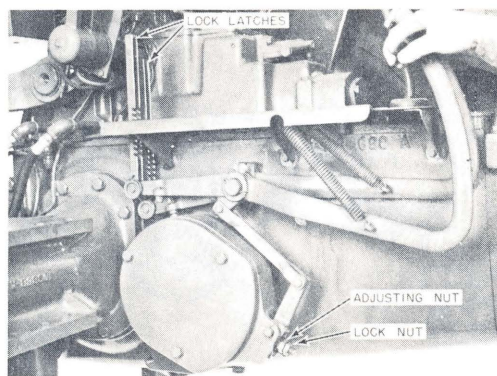

Fig. 10 Checking brake pedal adjustment.

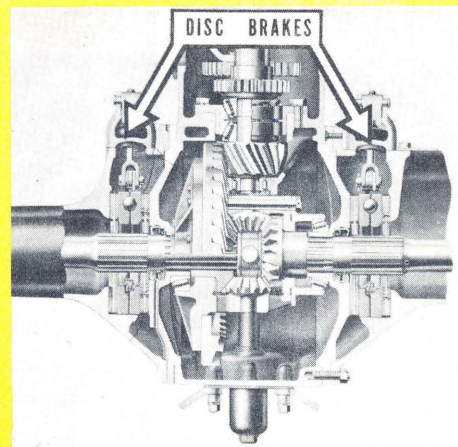

Fig. 9 Mechanical disc brakes.

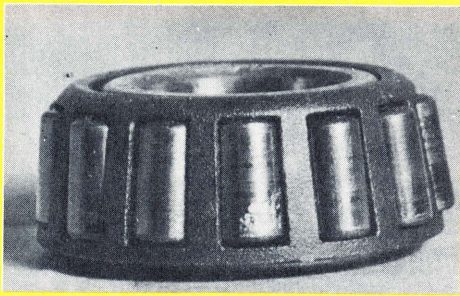

Fig. 11 Front-wheel bearing chipped because it was run too loose for too long.

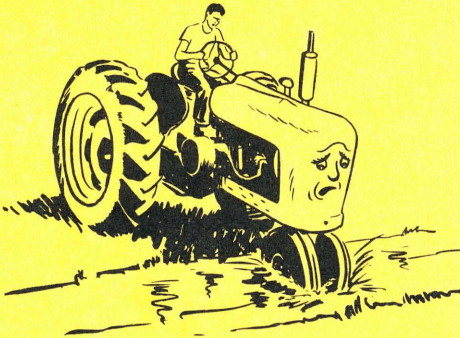

Fig. 12 If you get your front wheels wet—re-lubricate.

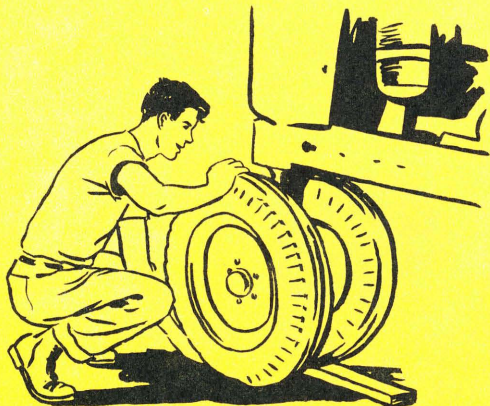

Fig. 13 Checking a front wheel for play.

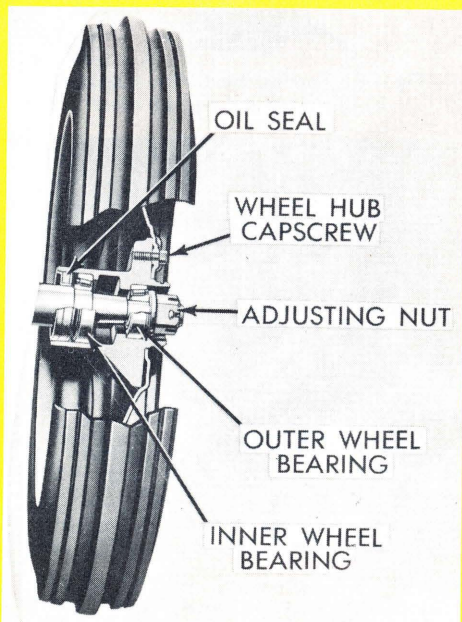

Fig. 14 How the front-wheel bearings are assembled.

Mechanically operated brakes may be adjusted by tightening the linkage between the brake pedal and the brakes, or by adjusting the band. If only one pedal can be locked, adjust it first and adjust the other brake to the same pressure. Adjustment methods vary from one make of tractor to another, with respect to free pedal clearance and procedure. The most important thing to remember is to adjust both brakes evenly.

SERVICING FRONT-WHEEL BEARINGS

Tractor front wheels usually work in dusty areas. Therefore, the front-wheel bearings are often subjected to needless wear because they are not kept properly adjusted or lubricated. A faulty dust seal, improper lubrication, and loose bearings are common causes of front-wheel bearing failures.

When a tapered roller bearing is run loose the outer edge of the bearing may become high; then, when the bearing is tightened, pressure will bear on the high ridge, causing the bearing to chip out. If a fine hairline is found on a bearing, it indicates wear from loose operation and the bearing should be replaced.

Operating a tractor with the front wheels under water is another cause of bearing failure. If your front wheels get into water up to the axles, they should be re-lubricated with the pressure gun if there is a fitting, or removed and hand-packed if there is no fitting. Re-lubricate the same day, if possible.

In irrigated sections where tractors are frequently operated in water, almost all front-wheel bearings are equipped with gun fittings so they can be lubricated every time they are stopped after being in water.

In cultivating corn, loading manure, etc., where the tractor carries the weight of attached equipment, an extra load is placed on the front-wheel bearings. Before attaching such equipment it is wise to check the bearings for proper adjustment.

To check the front-wheel bearings of a tricycle type of tractor, run one wheel up on a block of wood. This raises the opposite wheel and makes it easy to check for looseness. Reverse the process to check the other wheel. When you make this check, it's a good time to remove the front wheels, clean out the old grease, repack the wheels, and adjust the wheel bearings.

LUBRICATING FRONT WHEELS

Unless equipped with a grease-gun fitting, the front wheels of tractors are lubricated by hand packing the bearings with a grease suitable for wheel-bearings.

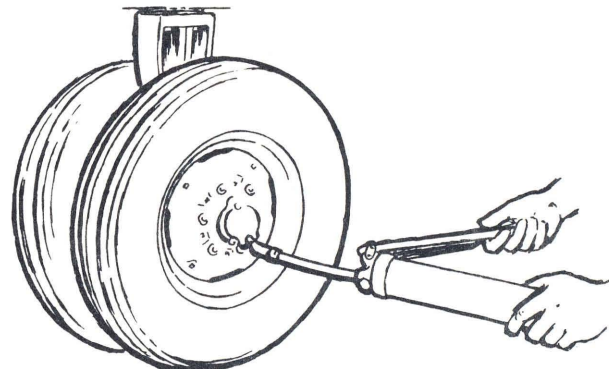

Fig. 15 Service front-wheel bearings with a grease gun if the tractor is operated frequently in water.



If wheels are to be lubricated with a grease gun the job should be done with care daily, or more often if necessary. Apply only enough grease to show a trace oozing out around the inner dust seal. This precaution is necessary to avoid damaging the dust seal. The fresh grease will displace the old, dust-laden grease and it will help form a new grease "collar" around the seal. With this method of lubrication, the wheels should be completely cleaned around the bearings at least once a year, the seals inspected, and the hubs refilled with pressure-gun or chassis grease.

Many tractor owners have changed from the gun-lubrication method to hand-packing the front wheel bearings with wheel-bearing grease. When such a change is made the wheel hub and bearings should be thoroughly cleaned and new dust seals installed. Pack only the bearing with grease. If you do so, close off the old fitting by hitting it with a hammer, or remove it and put in a solid plug.

HOW TO PACK A BEARING

To pack a bearing with grease put about a tablespoonful of grease into the palm of one hand and hold the bearing in your other hand. Take a small "bite" of grease with the bearing. Apply pressure on the palm of your hand and work the grease entirely through the bearing, "biting" into the grease until the whole bearing is packed. See that the individual rollers turn easily before returning the bearing to the wheel. Do not fill the hub with grease, because wheel-bearing grease may become "soupy" and damage the seal if too much is used.

When repacking a front-wheel bearing of the type that stays on the axle when the wheel is removed, check to see that the dust seal is in good condition. You then clean and repack the bearing without removing it from the wheel. If you cover the bearing with grease and then wrap a clean, lint-free cloth around it, it will help to work the grease into it.

If the inner bearing is of the type that comes off with the wheel, it will probably be necessary to drive it out of the hub before you can clean and lubricate it. To remove the inner bearing from the wheel hub use a large punch and be careful to drive only on the hard outer bearing race, so as not to harm the bearing. Better have your leader show you how to do it.

On some tractors a special seal is used and a lighter lubricant, such as motor oil or semi-fluid grease, is recommended. Always refer to your Operator's Manual for the recommended procedure for servicing the front-wheel bearings.

REPLACING THE FRONT WHEELS

When replacing or tightening the front wheels be careful not to injure the bearings and, at the same time, make sure the wheels are properly tightened. If a special seal is used, a special procedure is recommended so that the drag of the seal won't fool you into thinking that the wheel is tight when the bearings are still loose.

In general, the most common way to tighten front-wheel bearings is to turn the wheel slowly while adjusting the nut, until a definite drag is felt. Then the nut should be backed off to the nearest cotter-key hole (or from one-sixth to one-fourth turn). The wheel may have a slight drag. It should have no play.

DEMONSTRATION!



Fig. 16 How to pack a bearing.

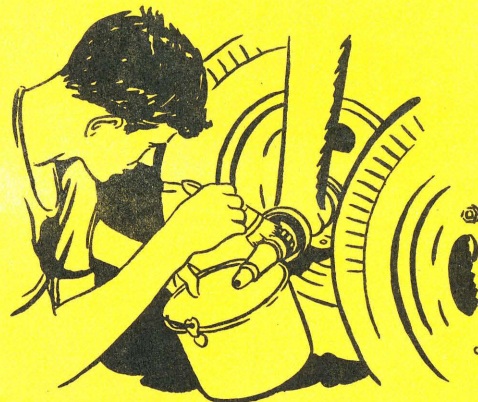

Fig. 17 Cleaning a bearing that stays on the axle.



Fig. 18 Forcing grease into a bearing, using a cloth and a screw driver.

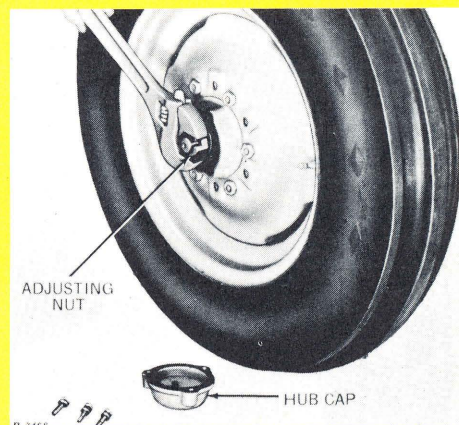

Fig. 19 Tightening a front-wheel bearing. Is this wrench being used correctly?



You will need your Operator's Manual to help you service your tractor and to answer the following questions.

1. What is the make and model of your tractor? _____
2. Does it have power steering? _____ If so, does it have its own oil supply? _____
How often should the oil level be checked? _____
3. What kind of lubricant is used in the steering gear case? _____
4. How much does the steering gear case hold? _____
5. How many grease fittings did you find to service on the steering gear, linkage, and front wheels?

What kind of grease should be used? _____

6. With the engine not running, check for looseness in the steering mechanism. What did you find?

7. Were you able to remove any of the looseness by adjustment? _____
Tell how this was done. _____

8. If you found some looseness that you could not remove by adjustment, tell what additional work is needed. _____

9. What kind of brakes does your tractor have? _____
10. Can they be locked together? _____
11. Check the brakes. How much free travel did you find in the pedals? _____
Right brake? _____ Left brake? _____
12. How much free travel should the pedals have? _____
13. Adjust the brakes. Tell what you did. _____

14. Does your tractor have hydraulic brakes? _____ If so, check to see if there is air in the system.
How can this air be removed? _____

Ask your dad if it is all right to clean and repack the front-wheel bearings on your tractor. Check your Operator's Manual first. On some tractors it is a good idea to replace the grease seals and retainers every time you repack the front-wheel bearings.

15. When you removed the front wheels, what did you find? What was the condition of the bearings?

Races? Grease seals? Retainers? _____

16. What kind of grease did you use for repacking the bearings? _____

17. To tighten the right wheel bearing, which direction does the nut turn? _____ Does the left one turn the same way? _____

ADDITIONAL NOTES _____

Note: Fill out this work unit, using your own tractor at home. Be ready to discuss your experiences with other 4-H members at your next club meeting.



THIRD YEAR UNIT 4

STEERING, BRAKES, AND FRONT WHEELS

Place the letter for the correct answer at the right of the page.

1. If the engine suddenly quits, a tractor that has power steering (A—will get out of _____ control) (B—will not get out of control because you can steer it manually).
2. On most types of tractors and trucks the steering gears and bearings are: (A—lubri- _____ cated with grease guns) (B—enclosed in an oil-tight case containing the lubricant) (C—oiled daily with a hand oil can).
3. A good method of checking for end-play in the vertical steering shaft is to: (A— _____ draw up on the steering wheel while the tractor is moving in reverse) (B—run one front wheel on a block and move the free wheel back and forth) (C—jack up the front end of the tractor and use a long bar under the front axle).
4. The main purpose of brakes on a tractor is (A—to help make turns at slow speeds) _____ (B—to make a quick stop every time you are finished with the tractor).
5. Tractor and truck front-wheel bearings are generally of the: (A—ball bearing) (B— _____ tapered roller bearing) (C—roller bearing) type.
6. A common cause of front-wheel bearing failure is: (A—operating tractor more than _____ three hours in hot sun) (B—faulty dust seal) (C—running with the bearing loose) (D—packing the bearing too full).
7. When packing front-wheel bearings: (A—use a rustproof type of grease) (B—soak _____ bearings in oil to remove the old grease and then rub the new on only the inner surface of the bearing) (C—work the grease entirely through the bearing).
8. Hubs (A—should) (B—should not) be filled with grease. _____
9. The most common way to tighten front-wheel bearings is: (A—to force the bearings _____ into place as tightly as possible) (B—to turn the adjusting nut counter clockwise until it drops into position and lock with a cotter key) (C—to turn the wheel slowly while tightening the adjusting nut until a drag is felt, then back the nut off to the first cotter key hole).
10. If the front wheels of a tractor or truck have been operated under water: (A—they _____ should be jacked up to allow water to drain) (B—they should be tightened afterward) (C—they should be removed, cleaned, and repacked with grease).

Note: This Check-Up Sheet is intended to test what you have learned and to stimulate discussion with the other members. The more you discuss these questions with your leader and the other members the more you learn.

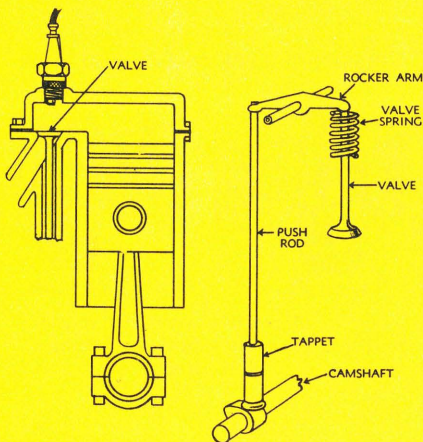

Fig. 1 Valves: (left) L-head engine; (right) valve-in-head engine.



Fig. 2 Camshaft gear is twice the size of the driving gear at lower right. Note timing marks.



Fig. 3 Checking compression by cranking the engine.



Fig. 4 A burned valve.

For an engine to run properly, the valves need to be working right. Valves are timed by means of gears so that they let out burned gases on the up stroke of the piston, or exhaust, and take in the fresh fuel mixture on the down, or intake stroke. Then, with all valves closed, the piston moves up on the compression stroke and down on the power stroke before the valves open again.

HOW VALVES WORK

Valves are opened by cams on the camshaft and closed by valve springs. The camshaft is driven by a gear on the crankshaft and turns only half as fast as the crankshaft. The gears must be properly meshed so that the valves will open and close at just the right time.

VALVE TROUBLES

Exhaust valves give the most trouble. The valve tappets may be set too close (not enough clearance). The valves can beat themselves down in the valve seats. Valve stems can gum up and hold the valves open. Valve heads can warp and leak. The oil line to the valves can plug up — many other things can happen to cause valves to give trouble. Any of these troubles can cause loss of compression (and power). Operating an engine with leaking valves will soon result in burned valves and costly repair bills.

CHECK COMPRESSION

Check the compression on your engine to see if any cylinders are leaking. You can do this by turning the engine over by hand (with the ignition off). As you turn it, you feel each piston come up on the compression stroke. Actually the pistons will “rock back,” if you let them do so as you pull up on the crank. With a four-cylinder engine, you should be able to feel a compression stroke on each half turn of the crank. With a six-cylinder engine, you will feel a compression stroke for each one-third turn on the crankshaft. You can tell which cylinder is on compression by removing the distributor cap and noting where the rotor points.

A more accurate way to check compression is with a compression gauge. If you do not have one, borrow one from the local shop. Before using the gauge, clean the area around the spark plugs and then remove all the plugs. Hold the gauge firmly in a spark plug hole and have someone run the engine with the starter. The throttle should be set at full speed so that a full charge of air can enter the engine. Your local shop mechanic can tell you what the gauge pressure should be.

If the compression pressure is weak on one cylinder there may be a leaking valve. Have it repaired at once. Let your serviceman do the repair work. He has a special machine for grinding valves. He and his employees are trained to do a good job with the machine. He may even have some new, improved parts such as a new type of valve or rotators, to install.

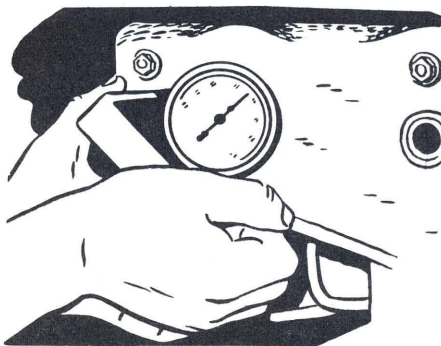

Fig. 5 Testing engine compression with a compression gauge.

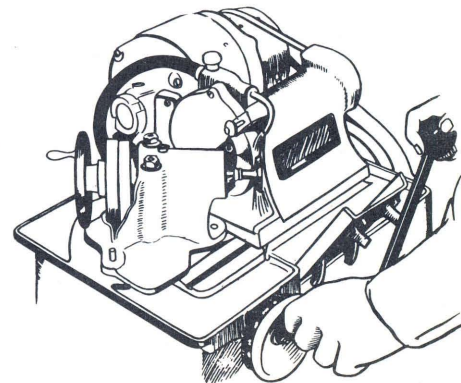

Fig. 6 A special machine for grinding valves.



VALVE ROTATORS

If you are having valve trouble with an older engine, inquire about valve rotators. Many manufacturers now have valve rotators available for their older tractor engines. Rotators are used on most of the later model engines. A valve rotator automatically turns the valve a short distance each time the valve is raised. Doing so helps to keep the face of the valve and the valve stem clean.

VALVE ARRANGEMENTS

Now let us look at some tractor engines to see where the valves are located. On some engines the valves are placed on the side of the engine block. We call this an L-head engine. The valves can be reached by removing two cover plates on the side of the engine. Note: The careful operator will always clean off the dirt before removing a cover plate.

Most tractor engines have the valves located in the head of the engine. We call this a valve-in-head engine. A cover is fitted over the top of the valves to keep out dirt and prevent oil leaks. It can be easily removed for servicing the valves.

Have a new gasket ready before you remove the valve cover or cover plate. You will probably spoil the old gasket and will have an oil leak if you do not install a new one.

CHECKING VALVE LUBRICATION ON VALVE-IN-HEAD ENGINES

To obtain long valve life, valve stems of exhaust valves must be lubricated. In most valve-in-head engines, oil for the valves is carried through a small oil line to a hollow rocker arm shaft. The rocker arms are drilled to allow oil to flow down over the tops of the rocker arms to the valves. To keep excess oil off the intake valves, rocker arms are often made narrow on top so as to allow the oil to drain off before it reaches the valves. On some exhaust rocker arms you find a channel to carry the oil to the valve stem. Seals are used to keep excess oil from intake valve stems. Too much oil on intake valves causes high oil consumption.

Whenever you have the valve cover off, you should run the engine for a short time and check valve lubrication. Make sure that all exhaust valves are receiving a good supply of oil. If no oil is flowing to the exhaust valves, check the small oil line leading to the rocker arm shaft. It may be plugged and in need of cleaning.

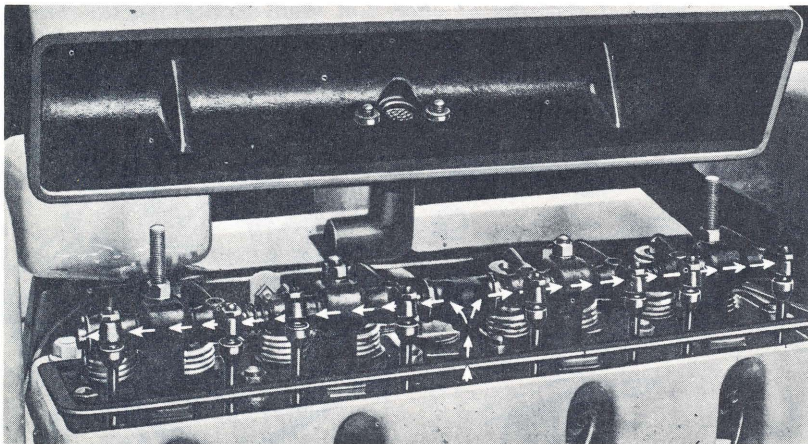

Fig. 11 Arrows show how oil flows to valve stems in a valve-in-head engine.

POSITIVE TYPE VALVE ROTATOR

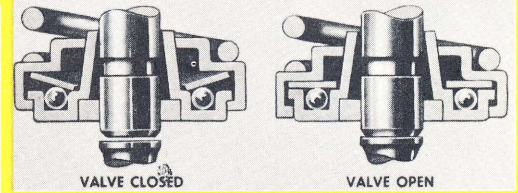

Fig. 7 A positive type valve rotator turns the valve slightly each time it is lifted.

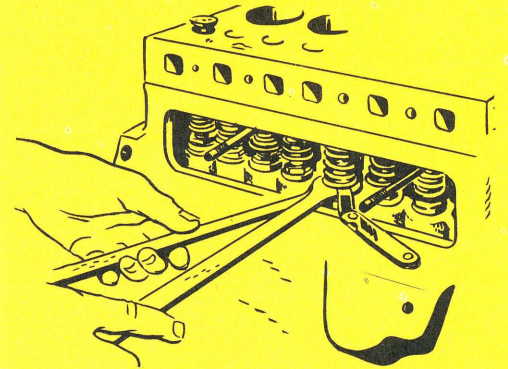

Fig. 8 Adjusting tappets on an L-head engine.

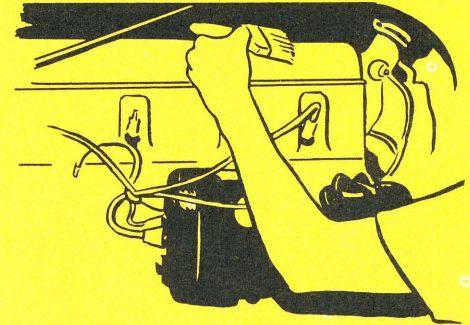

Fig. 9 Clean dirt off your engine before removing valve covers.

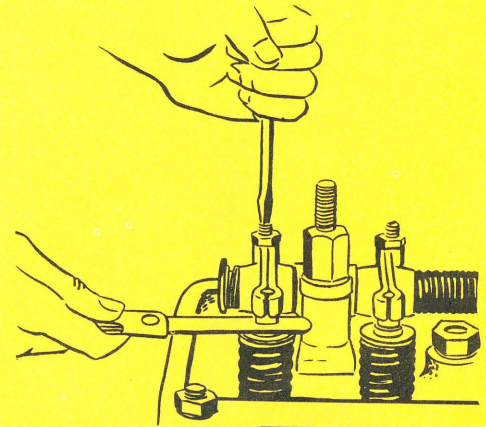

Fig. 10 Tappet adjustment on a valve-in-head engine.

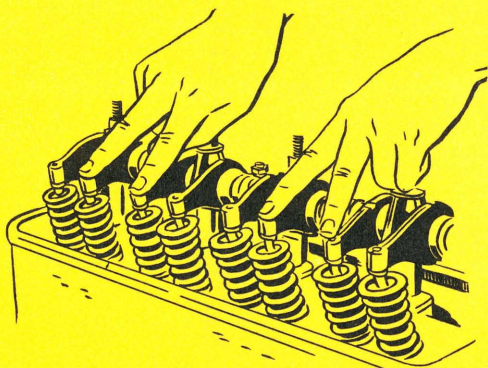

Fig. 12 Finding the firing order of a four-cylinder engine.

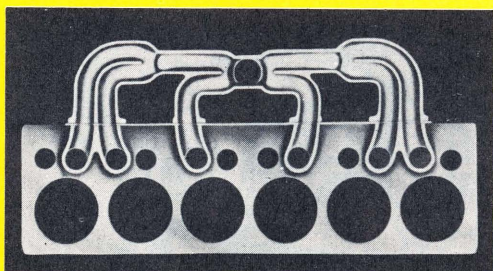

Fig. 13 Intake manifold and valve arrangement for a six-cylinder engine.

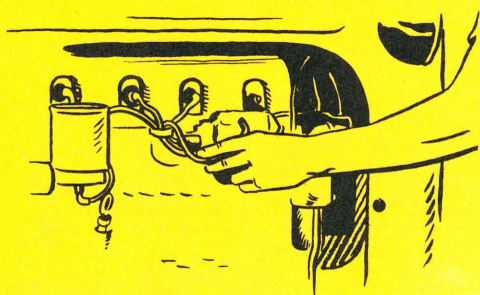

Fig. 14 Find out the firing position of each cylinder by pulling all the spark plug wires. Then turn the engine over until you see a spark at the wire you are checking.

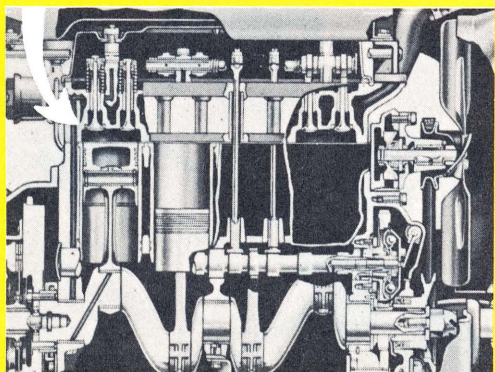

Fig. 15 Exhaust valve (arrow) on No. 4 cylinder is just closing—No. 1 cylinder is ready for firing.

CHECKING FIRING ORDER

Checking the firing order by watching the motion of the intake valves makes a good demonstration. It will also help you to understand how the valves open and close. In a four-cylinder engine, the valve nearest the crank is an exhaust valve. The next two valves are intakes, then come two exhausts and two intakes. The last valve on the end is another exhaust. This order always holds true for all four-cylinder engines having two intake ports (each serving two cylinders). You can look at the intake manifold and easily determine if two cylinders get their fuel mixture from one port.

To find out the firing order, place your fingers on the intake valves. Have someone turn the crank and note the order in which the intake valves open. One valve will open every half turn of the crank. Actually you need only check the first two valves for a four-cylinder engine. The firing order is either 1-2-4-3 or 1-3-4-2.

To figure out the firing order of a six-cylinder engine, find the intake valves and follow the same procedure. The only difference is that in a six-cylinder engine, an intake valve opens every one-third turn. The most common firing order used on six-cylinder engines is 1-5-3-6-2-4.

ADJUSTING TAPPETS

Valve tappet clearance on a tractor engine should be checked every 200 to 300 hours of operation. On some engines the valve tappets should be set with the engine cold, while on others the engine should be hot. Your Operator's Manual will tell you if the engine should be hot or cold and will list what the clearance should be.

Unless you have had a lot of experience in adjusting tappets, it is best to do this job when the engine is stopped. The engine should be in the firing position before the tappets are adjusted. An easy way to find out the firing position of each cylinder is to remove all the spark plug wires and place them close to the engine block. Then turn the engine until you notice a spark at the wire for the cylinder nearest the crank, or the No. 1 cylinder. That's its firing position.

Another easy way to locate the firing position of the No. 1 cylinder when you have the valve cover off is to watch the valve action. Remembering that the No. 1 piston comes up at the same time as No. 4, all you need to do is turn the crank until the back valve (exhaust valve) just closes. This tells you that the back cylinder has just completed the exhaust stroke. The No. 1 cylinder has just completed the compression stroke and is ready for firing.

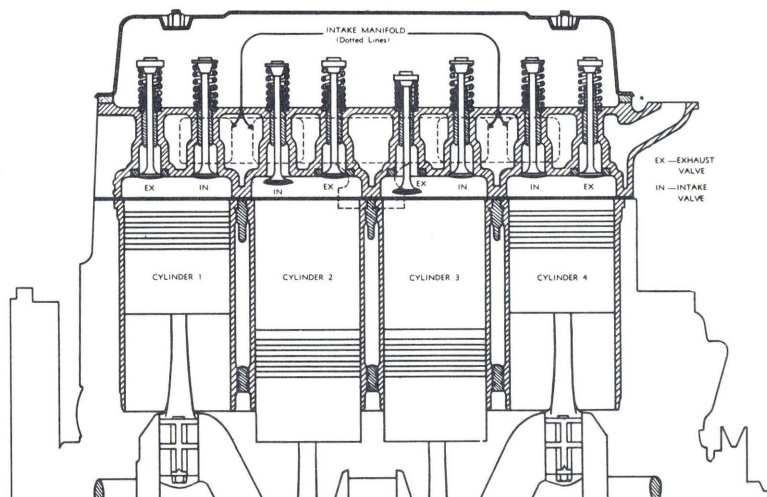

Fig. 16 Valve and cylinder arrangement—four-cylinder engine.



After finding the proper position for adjusting the No. 1 cylinder, turn the crank one-half turn (for a four-cylinder engine) and adjust the tappets for the next cylinder in the firing order. If the firing order is 1-3-4-2, this will be the No. 3 cylinder. If the firing order is 1-2-4-3, this will be the No. 2 cylinder. On a six-cylinder engine, turn the crank only one-third turn between adjustments. If your engine has a magneto, the click of the impulse tells you when to stop turning.

CAUTION: When adjusting the valve tappets, it is a good idea to go back and check your adjustment to make sure that you don't have a tappet too tight. It is better to leave an adjustment a little loose rather than have it too tight. This is especially important on exhaust valves.

When making adjustments, always use two feeler gauges—one that will go through easily, perhaps a 10/1,000th (.010) gauge, and one a little larger, about a 12/1,000th (.012). Refer to your Operator's Manual for the proper valve clearance for your tractor. The larger gauge should not pass through the clearance. If there is someone nearby who has adjusted tappets, it is a good idea to have him check your adjustment.

HOW TO AVOID VALVE TROUBLE

Some of the older engine designs did not provide good valve cooling because the heat had to travel too far from the valve head to the cooling water. Sometimes the local repair shop can make changes that will relieve cooling trouble. Certainly the operator can help by keeping the cooling system clean and not using hard or dirty water in the radiator. Fuel that has been in storage a long time can often cause trouble by leaving gummy deposits in the valve guides. Valves also give more trouble when the engine is allowed to run too hot. Let the engine idle and cool gradually before stopping it after doing heavy work.

Remember that a lean mixture results in slow burning and that the hot gases passing the exhaust valves can cause them to overheat. Use a richer mixture to extend the life of valves.

Valve overhauls must be done right if the job is to last. Loose valve guides do not give proper cooling. Weak valve springs do not close valves properly. Valves ground to a sharp, thin edge do not cool as they should. Wide valve seats catch carbon and cause other heat troubles.

When a valve overhaul job is necessary, take your tractor to your local implement dealer. Have the whole engine checked to see that other difficulties are not the real cause of the valve trouble. For example, a restricted exhaust could cause enough back pressure and heat to burn valves; the cooling system could be limed, etc.

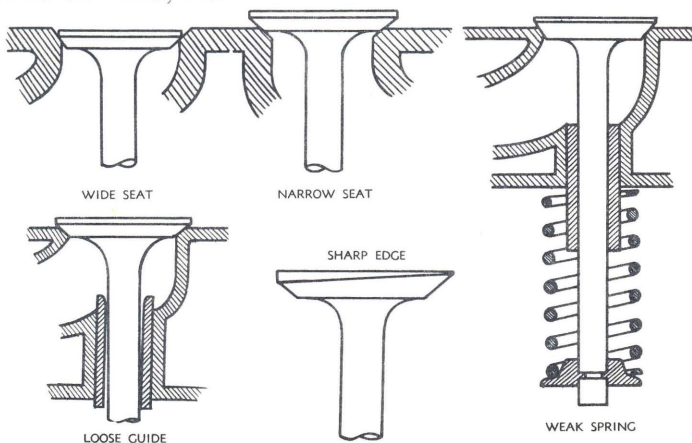

Fig. 21 Some valve troubles which might be found in your engine.

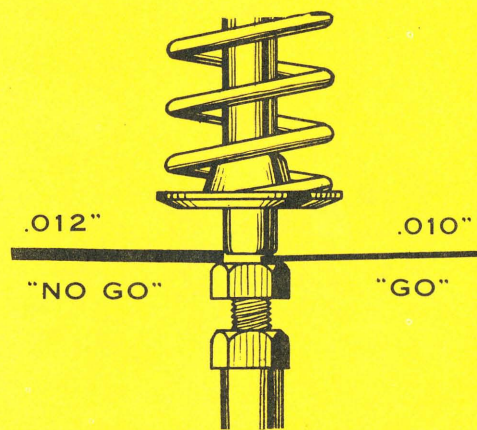

Fig. 17 Use two feeler blades in adjusting tappets.

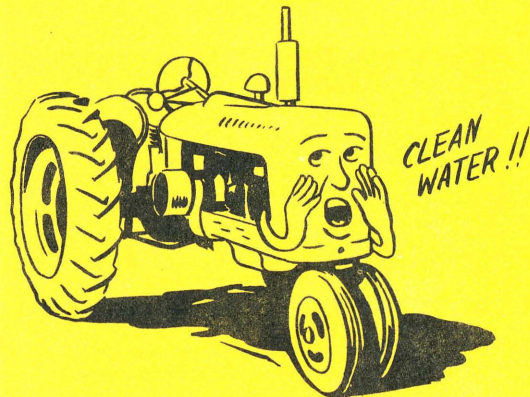

Fig. 18 Your tractor calls for clean water.

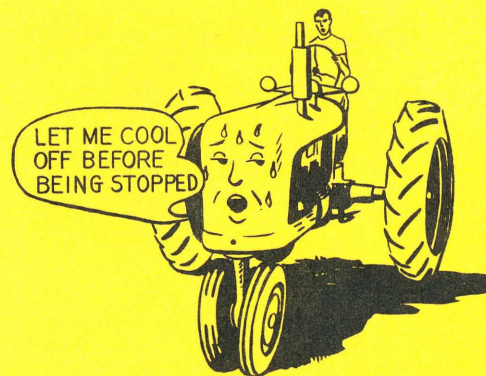

Fig. 19 Let the engine cool off gradually before stopping.



Fig. 20 Check the muffler for restrictions, dirt, etc.



Roll up your sleeves and let's get at this valve checking job. You may not need to change the tappet clearances; but you do want to know how and what you are checking.

1. Have the throttle open and the ignition off. Turn the engine over and see if you can feel the compression on all cylinders. Four cylinders, four compression strokes, two revolutions of the crankshaft. If it is a six-cylinder engine, you should be able to feel three compression strokes for each revolution of the crankshaft, six for two turns. Do any of the cylinders feel soft? _____ If so, have someone crank the engine while you listen at the exhaust. If you hear a "hiss," probably a valve is leaking.

How many cylinders feel as if they are losing compression? _____ How many hours has this engine run since new or an overhaul? _____

Clean the engine before removing cover plates, pans, or plugs. _____

2. If you can borrow a compression gauge, try it on all cylinders with the plugs out and the throttle open. Record the readings for each cylinder.

1 _____ 2 _____ 3 _____ 4 _____ 5 _____ 6 _____

Which cylinder is low in compression? (To check, turn engine to the point where the compression seems weak, remove distributor cap, and note where rotor points.) _____

3. Learn how the valve stems and valve lifters are lubricated. Were the oil lines open and working? _____

How is the oil kept off the intake valves? _____

4. What is the firing order of your engine? _____

Check it by watching the spark at each plug wire. Also check it by watching the intake valves.

Where on the engine is the firing order marked? _____

5. What is the recommended tappet clearance on this engine for: the intake valves? _____

the exhaust valves? _____ hot or cold _____ . What clearances did you find with the gauge?

_____ Is the engine a "valve-in-head" or "L-head"? _____ Does your tractor have valve

rotators? _____

6. Does the engine have a breather cap on the valve cover? _____ Did you clean it? _____

7. Report anything else you did on the engine. Tell what value this work unit has been to you. Has

it helped with better tractor operation at home? _____

Note: Fill out this work unit, using your own tractor at home. Be ready to discuss your experiences with other 4-H members at your next club meeting.



THIRD YEAR UNIT 5

VALVES AND VALVE SERVICE

Place the letter for the correct answer at the right of the page.

1. As you crank an engine and the piston comes up to top dead center, the compression _____ is probably: (A—faulty) (B—good) if the cylinder rocks back as you release your hold on the crank.
2. The best method of testing compression is: (A—by cranking and observing piston _____ action) (B—by putting your thumb in a spark-plug hole and feeling pressure) (C—by use of a compression gauge).
3. In using a compression gauge, you put it: (A—into the exhaust stack) (B—into the _____ No. 1 cylinder spark-plug hole) (C—into every spark-plug hole in turn).
4. If you find that compression is weak, the best thing to do is to: (A—use a heavier _____ oil) (B—pour liquid solder in the cooling system) (C—take the tractor to a recommended service man).
5. Any time you remove such parts as spark plugs, distributor or valve covers, and the _____ like from your tractor, be sure to: (A—write down a list of each part removed) (B—clean parts in fuel) (C—remove all dirt from around the parts before removing).
6. As you adjust each set of tappets be sure: (A—that the piston for that cylinder is in _____ firing position) (B—that the ignition is turned off) (C—that you don't get your fingers caught in the whirling fan).
7. Four-cylinder engines can have the following firing order (two are correct): (A—1-3- _____ 4-2) (B—1-2-3-4) (C—4-3-2-1) (D—1-2-4-3).
8. The best method of gauging the valve tappet gap is: (A—to use two gauges, one _____ slightly thicker than the recommended gap and one of the right measurements) (B—to place the gauge of the correct measurement in the opening and tap it with a screw-driver to see if it will pass through) (C—use a thin dime).
9. Lubrication of valves is provided by: (A—oil splashing up from crankcase) (B—a _____ small oil line which carries oil under pressure to the rocker arms) (C—oil vapors rising from below).
10. Loose valve guides may be harmful to your tractor engine because: (A—they cause _____ a rattling noise) (B—they do not provide proper valve cooling) (C—they make your engine run too cool).

Note: This Check-Up Sheet is intended to test what you have learned and to stimulate discussion with the other members. The more you discuss these questions with your leader and the other members the more you learn.

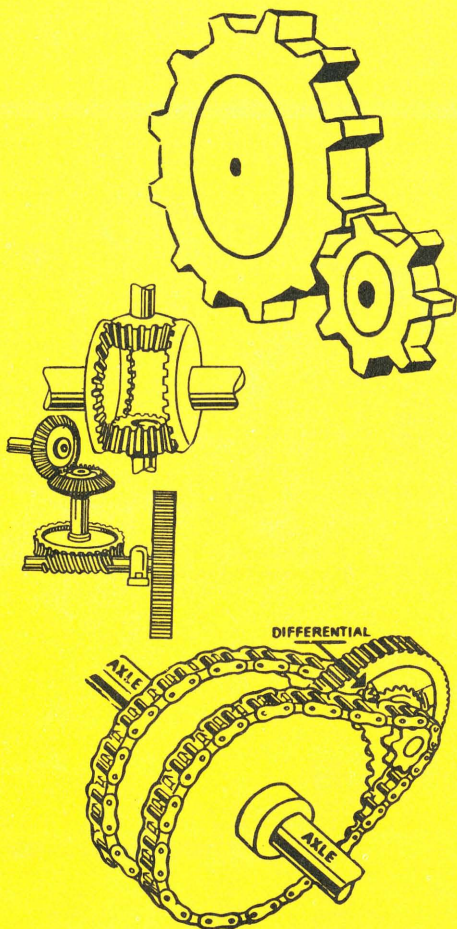

Fig. 1 Spur gears, bevel gears, worm gears, chains—all can be used to transmit power.



Fig. 2 Gears are like a long lever.

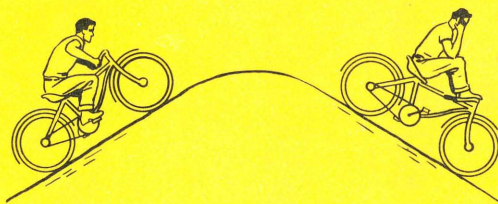

Fig. 3 Riding a bicycle up and down a hill is a good example of how torque and speed are related.

When an engine runs it develops power. By that we mean that the engine gives a turning force at the crankshaft. This turning force is called torque. Torque and speed together give power. When more torque is needed for pulling heavy loads, we reduce speed.

HOW GEARS WORK

Gears are used to change speed in a tractor. Reducing the speed increases the torque or pulling ability. Gears can be used also to increase speed. Doing so reduces the torque. Gears are used to take power around corners and to make shafts turn in opposite directions. Gears are also used to make engine valves open at the right time and to make the spark occur when we want it. Some gears mesh with each other. Some are connected by chains.

The speed of the shafts turned by gears varies as the number of gear teeth varies. If a large gear having 28 teeth drives a small gear with 14 teeth, the smaller gear will turn $28/14 = 2/1$, or twice as fast.

Gears are much like levers. If you tried to lift a heavy anvil singlehanded, you would be out of luck. But by using a long lever you alone can easily lift the anvil. Gears are levers in disguise. Big gears — long levers; little gears — short levers. Your engine provides the power; and when you select the gear you are going to use, you are really picking a lever of the right size for the work the engine must do.

The gears turned by the engine can do two things—they can change the torque or turning force and they change the speed. Power equals torque multiplied by speed. Now let's see how this works.

If you are riding your bicycle along at a good clip and come to a hill, what happens? You have to put on more power (more torque and less speed). That's the formula working. If you don't pump harder, you slow down because more of the power has to go into torque instead of into speed. Coming down the other side of the hill, your speed will pick up because you won't need so much turning power and the same amount of power or pumping on the pedals will increase your speed (more speed and less torque). The governor on your engine keeps the tractor moving at constant speed. If you hit a tough spot in the field and the tractor slows down you may kill the engine. To keep from stalling, it is necessary to change the gear ratio. The gear ratio is changed by meshing a different set of gears in the transmission.

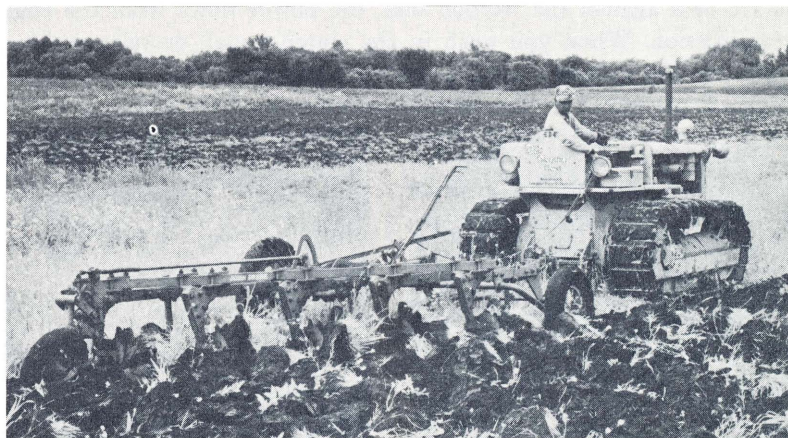

Fig. 4 Your engine governor keeps the tractor moving at constant speed.



TRANSMISSION

There are many gears in the transmission of your tractor. Some are arranged so that you can shift them on a shaft. Doing so changes the speed of the rear wheels. In most transmissions, the upper shaft is called the countershaft. The gears on this shaft can be moved back and forth. This shaft is connected by a clutch to the engine. The lower shaft or drive shaft is connected to the final drive and rear wheels. By shifting a gear on the upper shaft to mesh with a mating gear on the lower shaft, speed of the tractor is changed.

In low gear, for instance, you connect a small gear on the countershaft with a larger gear on the lower shaft. In second gear you use a slightly larger drive gear and a smaller gear on the lower shaft. A large number of gears enables you to have many speed changes. Thus you can pick just the right speed to keep the engine working at its best. An engine runs most efficiently when it is operated at its rated speed and load. The clutch is used to disengage the engine from the transmission while shifting gears. Otherwise it would be difficult to mesh gears while they are moving at different speeds, or to unmesh gears while they are under load.

MULTI-SPEED TRANSMISSIONS

Nearly all of today's tractors can be made available with a wide selection of forward and reverse gears. As many as twelve forward and three reverse gears can be selected on some tractor transmissions. By selecting an exact speed for the job, you can get the most efficient use from your tractor.

In some cases it is possible to shift gears or speed ranges without using the engine clutch. This is made possible with the help of such equipment as planetary gears, torque converters, gear synchronizers, and additional clutches. Check your Operator's Manual to be sure you know how to use the transmission on your tractor.

CLUTCH

A good way to demonstrate how a disc clutch works is to do as follows: Place a half-dollar between two quarters and pinch the quarters tightly with your thumb and forefinger. Have someone try to turn the half-dollar. Then loosen your grip slightly, and he can turn the half-dollar easily.

This is the way a single-disc clutch works. There are two plates and one friction disc. One plate revolves with the fly wheel and the other is attached through a grooved arrangement called a spline, to the shaft leading to the transmission. The spline is used so that the back plate can be moved back and forth while rotating to apply pressure on the friction disc. When both plates are held against the friction disc, the power flows from the engine to the transmission. When you push in the clutch pedal, or release the clutch with a lever, the movable plate is pulled away from the clutch disc. Thus, the engine is permitted to turn without turning the drive shaft.

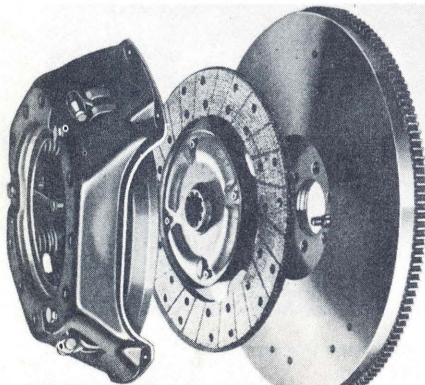

Fig. 9 A single-disc clutch.

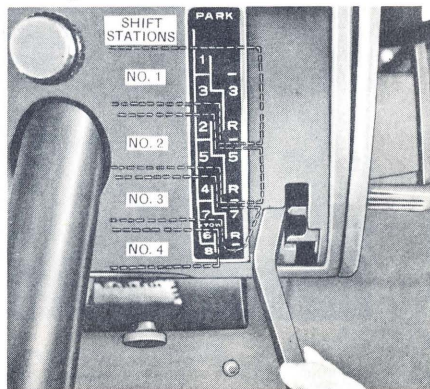

Fig. 8 Modern tractors have a wide selection of gears.

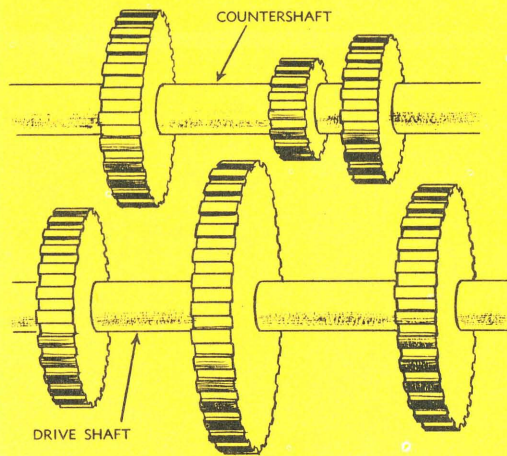

Fig. 5 Neutral gear—drive shaft disconnected from engine.

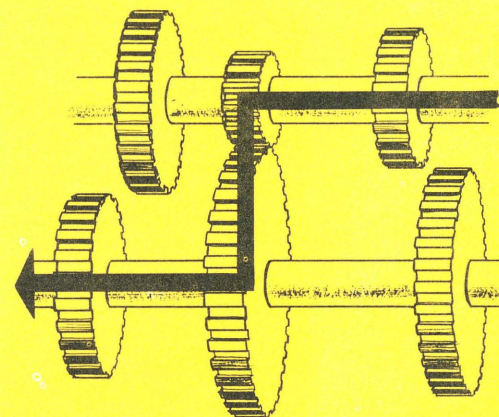

Fig. 6 Low gear—small gear on countershaft meshes with large gear on drive shaft.

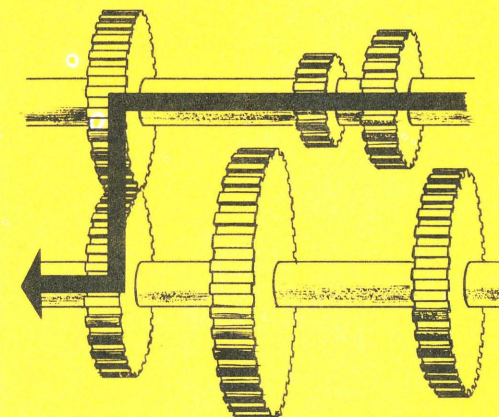

Fig. 7 High gear—larger gear on countershaft meshes with smaller gear on drive shaft.

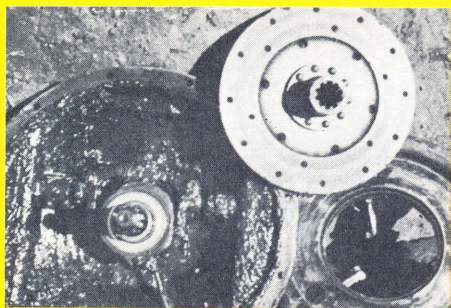

Fig. 10 Too much grease on a clutch throw-out bearing almost ruined this clutch.

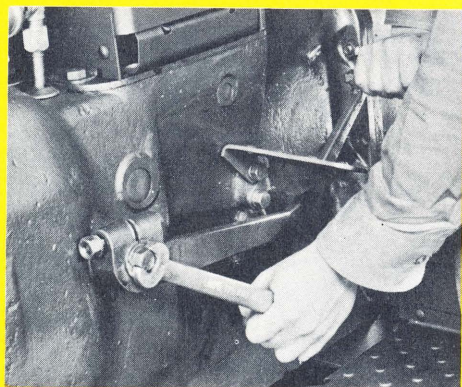

Fig. 11 Adjusting the free play of the clutch pedal.

The multiple-disc clutch works much the same as the single disc. The big difference is that several discs are used so as to obtain more frictional area.

When you let up on the clutch pedal, strong springs push the plate against the clutch disc. Some clutches have an over-center arrangement which locks the clutch. If you don't fully engage the clutch, the plate is not held tightly against the friction disc. The clutch may slip and overheat. We call this "riding the clutch." When engaging the clutch you should do so slowly to avoid a jerky motion when full power is applied suddenly through the gears.

If you put too much grease on a clutch throw-out bearing it is likely to get onto the face of the clutch, causing it to slip. This would be about like putting a little oil on the half-dollar in the demonstration just described.

On many tractors there are adjustments on the clutch. The tension on the springs can be adjusted, or the length of the arm that controls the clutch can be adjusted. Your Operator's Manual will tell you how to adjust the clutch on your engine. A clutch that slips will soon burn out. Keep the clutch in proper adjustment.

Some tractors have more than one clutch so that power can be transmitted continuously, either to the power-take-off shaft, or the belt pulley, or both, when the tractor drive clutch is released.

DIFFERENTIAL

From the transmission, the power goes to the differential. A differential takes the power around corners. It also makes one wheel speed up as the other slows down in turning. If you make a short turn by stopping the inside wheel, the outside wheel will go twice as fast.

You may compare the action of the differential to marching soldiers. When soldiers make a turn, the man on the inside slows down or stops as he waits for the men on the outside to come around.

In a differential, there is a small gear on the end of each axle. Each axle turns a wheel. Two or three small bevel pinion gears connect to these two gears. The bevel pinion gears are attached to a case, which is bolted to a larger gear called the ring gear. When the tractor is running straight ahead, the gears on the ends of the axles turn with the ring gear. The bevel pinion gears do not turn. They are carried around by the carrier.

Now, if the tractor is turned, one wheel slows down and the small bevel pinion gears turn, thus making the outside wheel speed up. The outside wheel speeds up at the same rate that the inner slows down. If you should turn a sharp corner and stop the inside wheel, the bevel pinion gears cause the outside wheel to turn at just twice the speed.

FINAL DRIVE

The final drive is the last link between the power of the engine and the wheels. It can be a chain or gear drive located within the differential, or a special gear drive located outside the differential case. In some tractors, the wheels and axles are attached directly to the differential just as in an automobile (no final drive).

If the tractor has final-drive cases, be sure to check the lubricant level in the cases. The lubricant should be changed in these cases when the transmission is serviced.

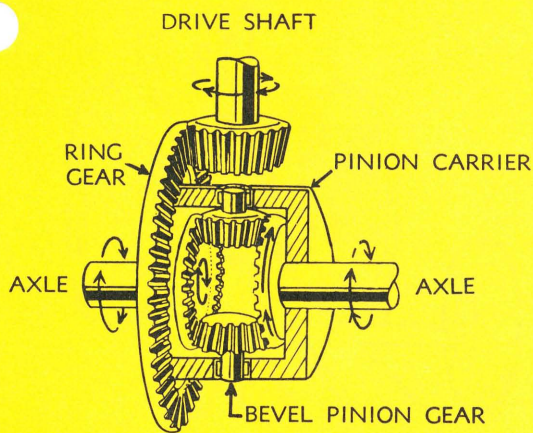

Fig. 12 Here are the parts of a differential.

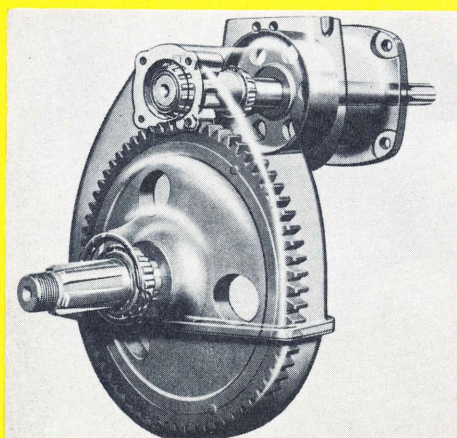

Fig. 13 A final drive—gear type.



In some tractors, final reduction is made by a set of planetary gears at each end of the rear axle. The center gear of the planetary system is called a sun gear. As it turns it causes the pinion (planet) gears to roll around the ring which is stationary. The ends of the pinion gears are fastened to a carrier which in turn is splined to the stub axle shaft. As the sun gear turns, the pinions roll against the ring gear, causing the carrier to turn the rear wheel. Do you know why we call it a planetary system?

Each planetary system has its own supply of lubricant and needs to be serviced periodically. The bearings that holds the gears and stub axles are splash lubricated by the oil in the planetary system.

BELT POWER

We also use our tractor engine to supply belt power. The belt speed of tractor engines has been standardized at 3,100 feet per minute, (plus or minus 100). This is the speed a fly on the belt would be traveling if he could hang on. Belt speed is always given for properly governed engine speed. Large pulleys turn slower and small pulleys turn faster to furnish the correct belt speed.

To determine belt speed, find out how many feet the fly would travel in one revolution of the pulley and multiply by the number of revolutions the pulley makes in a minute. Your Operator's Manual will list the belt speed.

Make sure you use the proper size of pulley on the driven machine. If you slow down a machine by slowing down the tractor engine, your engine may work poorly on a belt load. You will probably think it doesn't develop full power. It would be better to use a larger pulley on the machine.

When doing belt work use a belt about as wide as the pulley. Drive a stake in the ground at the edge of the belt so it will not rub on the tire. Ground the tractor with a chain to eliminate static electricity so that you won't get a shock and so that sparks will not cause trouble.

HOW TO FIND SPEEDS

Suppose you want to know if your tractor engine is running at the correct speed when doing field work. First take off the main ignition wire to make sure the engine won't start. Then put the tractor in the gear you intend to use. Now crank the engine and count the number of engine turns for one turn of the rear wheels. Say that you find this to be 60. This is the reduction ratio (60-1). Count the revolutions that a rear wheel makes in one minute. Say that this is 25. Then $25 \times 60 = 1,500$ rpm, which is the engine speed.

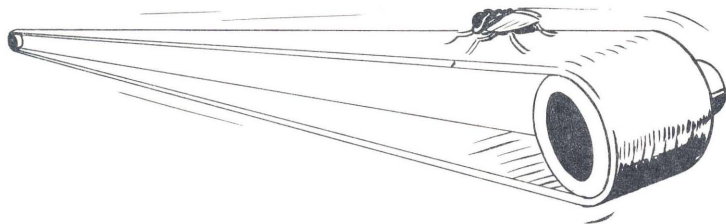

Fig. 18 Belt speed is the speed a fly on the belt would travel.

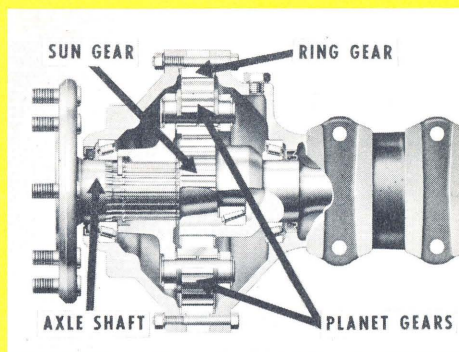

Fig. 14 A final drive—planetary type.

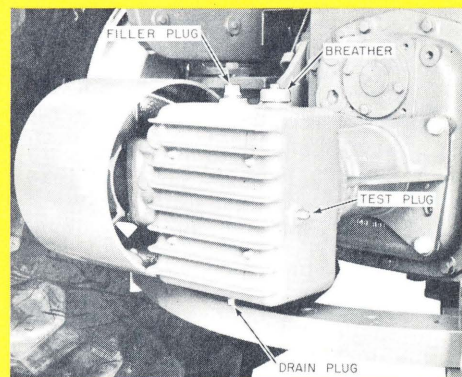

Fig. 15 A rear-mounted belt pulley.

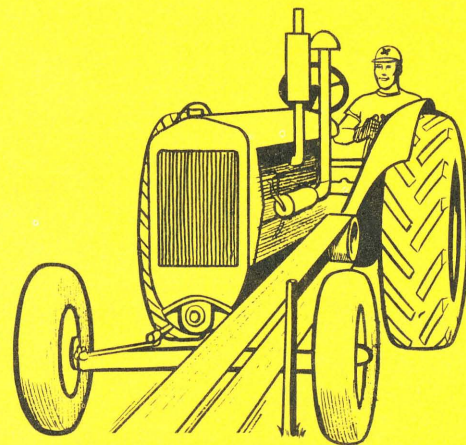

Fig. 16 Use a belt about as wide as the pulley—use a stake to keep the belt from hitting the tire.



Fig. 17 A cloth tied to the wheel makes it easier to count turns.

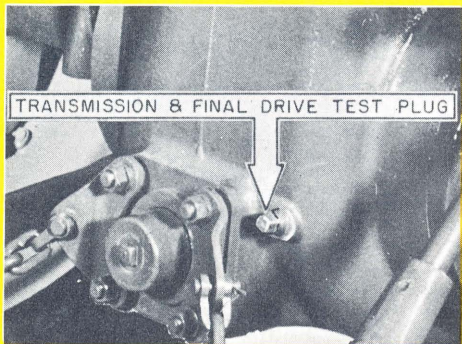

Fig. 19 Maintain the level of the transmission oil.

DEMONSTRATION!



Fig. 20 Using a magnet is a good test for metal particles in your gear lubricant.

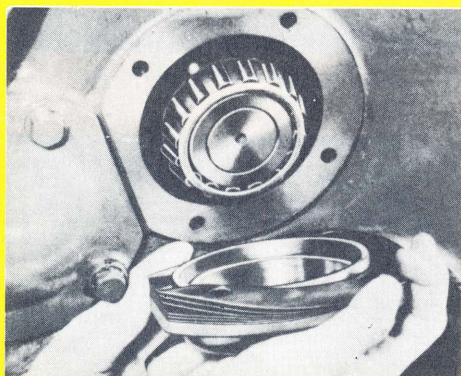

Fig. 21 Bearings can be adjusted by adding or removing shims.

SERVICING POWER TRANSMISSION PARTS

Tractor transmission parts are built of strong steel. The gears are assembled on shafts which turn on large ball or roller bearings. These parts are protected by an oil film. The gear case holds the supply of lubricant which clings to the turning gears and is splashed and carried to all the working parts. Most of the heavy anti-friction bearings (another name for ball or roller bearings) in tractor transmissions and final drives are located above the level of the lubricant. The lubricant is carried up to the bearings by clinging to the gears.

It is important that the oil level be maintained at the correct height. If the oil is low, the gear lubricant will not be carried to the bearings by the gears. If there is too much oil, the lubricant may overheat and leak out. In cold weather it is necessary to use a lighter gear lubricant—light enough to be carried up to the bearings.

Keeping the bearings properly adjusted is essential for longer gear life. The job is best done by your tractor mechanic.

Neglecting to change gear lubricants leads to costly repair bills. Oil becomes contaminated with dirt, metal particles, moisture, and rust. Because gear oils are heavy, most of the dirt finding its way into the transmission case gets carried up to other parts by the lubricant. Gears and bearings may thus be damaged. Gear lubricants should be replaced regularly as recommended in your Operator's Manual.

Many roller bearings have been ruined by hard dirt or metal particles rolling around between the rollers and the bearing races. Once a bearing becomes pitted, the damaged area soon hammers out. When a bearing becomes worn, the gears soon get out of alignment and will not last long before they break down completely. By proper adjustment of bearings and changing of the lubricant as recommended so as to remove the dirt and metal particles, tractor gears and bearings should last indefinitely.

It is easy to demonstrate that gear lubricant contains metal particles. To do so, drain about half a pint of lubricant from the transmission into a quart glass jar. Dilute it with an equal amount of kerosene. Place a strong magnet in the jar and stir. Remove the magnet and examine it for metal particles. These are probably bits of steel from normal gear wear, or possibly chipped from gears when they clash during shifting.

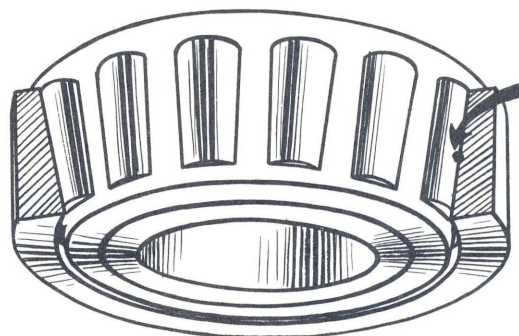

Fig. 22 Particles of dirt (arrow) can ruin this roller bearing.



DRAINING GEAR LUBRICANT

The tractor should be warm before gear lubricants are drained. If, for some reason, it is necessary to change the lubricant when it is cold, fuel oil should be added to dilute it. In some cases the plug for checking the level also serves as the opening for filling. If the case is filled to this level it will be necessary to tilt the tractor to add the fuel oil. To do so, drive one wheel on a block, or stop the tractor while heading down hill. Transmissions on some tractors have several compartments. When draining be sure to remove all the drain plugs.

On some cultivating tractors, a final-drive unit is located just inside each wheel. Such units usually carry a small quantity of gear lubricant. When draining them, use a metal trough to keep oil from the tire. Petroleum products are hard on rubber.

After draining a gear case, it is wise to flush it. To flush the transmission and final-drive cases, fill them to the recommended level with fuel oil or flushing oil. Then jack up one wheel and operate the tractor without a load for a few minutes.

After flushing, drain thoroughly and refill with the proper grade of gear lubricant. Your Operator's Manual will tell you the grade to use. Straight gear lubricants or heavy motor oils are usually recommended for farm tractors. If "EP" lubricants are not drained as recommended, they may cause rubber-like deposits in the transmission case.

TRACTORS SHOULD NEVER BE TOWED

On some tractors the engine must be turning the transmission gears to obtain proper lubrication. Towing such a tractor would result in poor lubrication and high shaft speed. The failure of many tractor transmissions can be traced to towing.

If the transmission gears are operated at excessively high speeds, the gear lubricants will become overheated. Overheating a lubricant causes it to oxidize and thicken. Continuous overheating would result in transmission failure.

When towing a tractor there is danger, too, that a brake may grab. The tractor may bounce and be hard to steer. If the tires are filled with liquid, the high speed can damage a tire.

If it becomes necessary to tow a tractor, do so slowly. It is much better to haul the tractor or drive it under its own power. Some tractors have a lever that permits the transmission gears to be disengaged so the tractor can be towed.

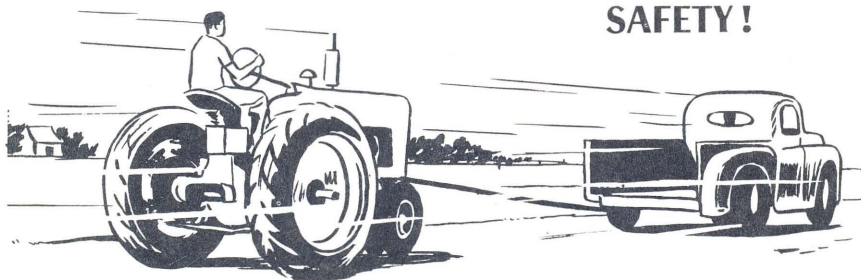

Fig. 27 "Headed for trouble"—don't tow your tractor at high speeds.

SAFETY!

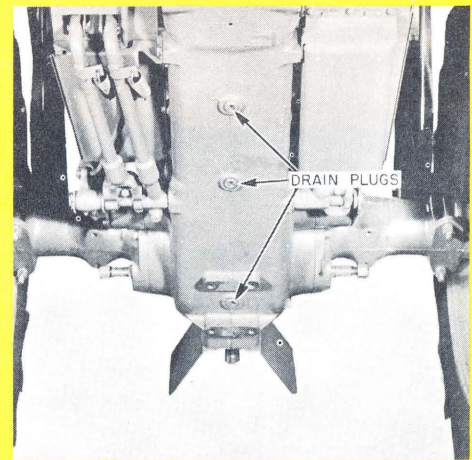

Fig. 23 Three drain plugs on this tractor for the transmission and final drive.

DEMONSTRATION!

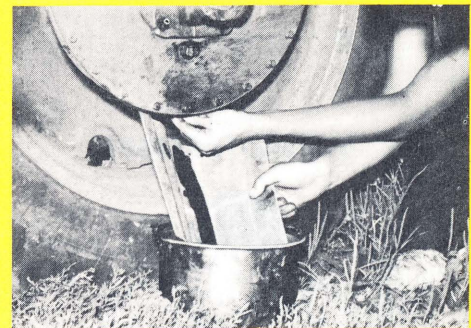

Fig. 24 A metal trough keeps gear lubricant off the tires.



Fig. 25 Transmission filler cap.



Fig. 26 Lever for disengaging transmission gears so tractor can be towed.



Answer the questions and do the jobs listed.

1. How many gears do you estimate are in your engine? _____
2. How many gears are in the power transmission unit? _____
3. Where do you find other gears on your machine? _____
4. How many speeds do you have on your tractor? _____
5. Do you have a single or multiple disc clutch on your engine? _____
6. Use your Operator's Manual and check the clutch for proper adjustment. _____
7. How is the clutch adjusted? _____

8. Did the clutch need adjusting? _____ Does the clutch run in oil? _____ How many clutches does your tractor have? _____
9. The centers of the rear wheels of a farm tractor are 60 inches apart. The wheels turn 30 revolutions per minute when going through the field. How fast will each wheel revolve when the inner wheel makes a turn 10 feet in diameter? Inner wheel _____ rpm. Outer wheel _____ rpm.
10. Do you have a brake on each rear wheel? _____
11. How do you apply the brakes? _____
12. Which brake do you use most? _____
13. Does your tractor have a final drive? _____ If so, how do you service it? _____

14. What is the governed speed of your engine? _____
15. What is the distance around the pulley? _____
16. How many times must you turn the engine to make the pulley turn 10 times? _____ What is the belt speed in feet per minute of your engine? _____ How fast (rpm) should the rear wheels turn in each gear? 1 _____ 2 _____ 3 _____ 4 _____ 5 _____

17. List the number of power transmission gear cases you have on your tractor. (If you have a gear case for the power-take-off or belt pulley, count these too.) _____
18. How much lubrication is required for each case? _____

19. Drain some lubrication from the transmission case and run the magnet test. What did you find? _____

(You might take some of the gear lubricant with you and make this demonstration at your meeting. You could collect samples and conduct this demonstration at a fair.)

20. Drain and service the gear cases on your tractor. How many drain plugs did you find in each case? _____

21. Refill all gear cases with new lubricant of the correct seasonal grade and list.

<u>Gear case</u>	<u>Kind of lubricant</u>	<u>Grade</u>	<u>Amount</u>
_____	_____	_____	_____
_____	_____	_____	_____
_____	_____	_____	_____
_____	_____	_____	_____

22. Do you ever tow your tractor? _____ At what speeds? _____
- _____
- _____

ADDITIONAL NOTES _____

Note: Fill out this work unit, using your own tractor at home. Be ready to discuss your experiences with other 4-H members at your next club meeting.



THIRD YEAR UNIT 6

POWER TRANSMISSIONS

Place the letter for the correct answer at the right of the page.

1. Gears are used to transmit power and reduce speed. When the shaft speed is reduced _____ the torque is: (A—the same) (B—reduced) (C—increased).
2. Low gear is obtained by meshing: (A—a small gear) (B—a large gear) (C—a gear _____ of the same size) with a larger gear on the driven shaft.
3. The main difference between a single disc and multiple disc clutch is: (A—the way the _____ clutch is engaged) (B—the size of the clutch) (C—the number of friction discs used). A second clutch may be used on some tractors: (A—in case the first clutch does not hold) (B—so the tractor can be stopped and the power-take-off shaft will continue to turn without interruption). Two answers.
4. The purpose of a differential is to: (A—keep the rear wheels turning) (B—give a dif- _____ ferent speed to each wheel when turning). When one wheel is stopped, the other wheel turns (A—the same speed) (B—twice as fast) (C—half as fast). Two answers.
5. A brake on each wheel assists in turning. When making a short turn apply the brake: _____ (A—suddenly) (B—lightly) (C—gradually after reducing speed).
6. The lubricant in the final drive should: (A—never be drained) (B—seldom be drain- _____ ed) (C—be drained whenever the transmission is serviced).
7. It is important to keep the gear lubricant at the proper level because the: (A—gear _____ lubricant is heavy and flows slowly) (B—the gears are located below the lubricant level) (C—the gears dip into the lubricant and carry it to the bearings).
8. In cold-weather operation with heavy loads for long periods: (A—part of the gear _____ lubricant should be drained) (B—more gear lubricant should be used) (C—the gear lubricant should be drained and the gear case filled to the proper level with a lighter lubricant).
9. If it is necessary to tow a tractor a short distance along a highway, it should be towed _____ at: (A—a very slow speed) (B—ordinary tractor operating speed) (C—high speed in order to get it off the road as quickly as possible).
10. When for any length of time transmission gears are forced to rotate at higher speeds _____ than those for which the gears are designed, the gear lubricant: (A—becomes very thin) (B—flies out of the gear case) (C—becomes overheated and thickens).

Note: This Check-Up Sheet is intended to test what you have learned and to stimulate discussion with the other members. The more you discuss these questions with your leader and the other members the more you learn.

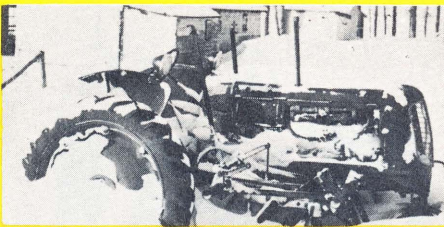

Fig. 1 Is this tractor properly stored?

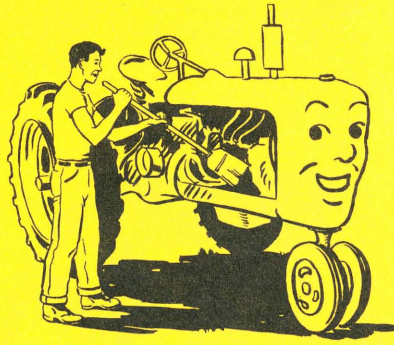

Fig. 2 Clean your tractor!

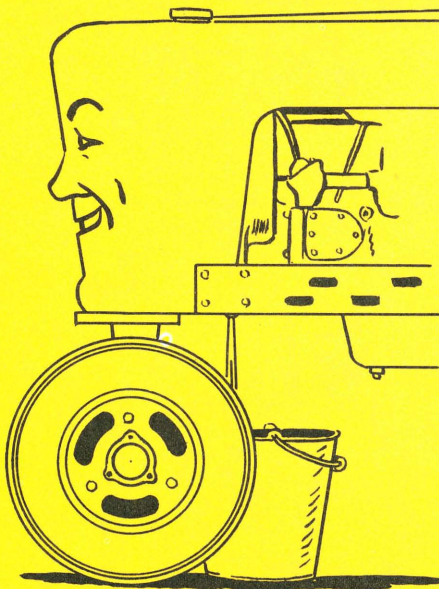

Fig. 3 Draining the radiator.

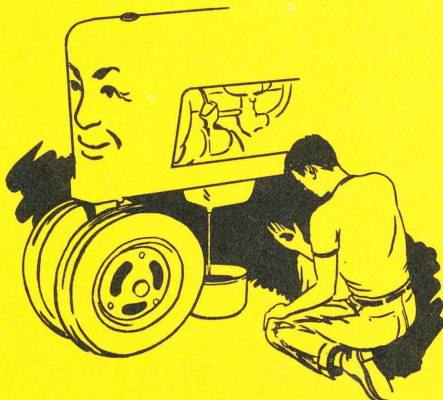

Fig. 4 Drain the motor oil.

An idle machine doesn't pay its way. Yet on many farms there are times when power is not needed. To protect a machine when it is not needed, it should be stored properly. When storing it, make sure that it will not rust and corrode while idle. Check it over, noting the parts which need adjustment or repair. Get the parts needed and repair the machine during the slack season. Then it will be ready when you need it.

If the engine needs overhauling, take it to your dealer during the slack season. Then he will have ample time to get all the parts needed and to do a thorough job for you. He will appreciate your helping to keep his men busy during the slack season.

If an engine or tractor is going to be used during cold weather, it should be winterized. To prevent a high rate of wear, the engine must be in good shape so it will start easily. Protect it with winter lubricants.

In the work unit on winter care you have several choices. You can prepare a tractor for storage, you can prepare a tractor for winter operation, or you can do both.

STORING A TRACTOR

All engines, regardless of where they are used, should be well protected while in storage. All parts of the tractor need to be lubricated and the bright metal parts covered with a rust preventive.

CLEAN IT

First of all, when preparing a tractor or engine for storage, clean it. Wash the tires. If a coat of oil and dirt covers the engine, scrape off the heavier part and then cover the remaining dirt with a cleaning solvent or kerosene. Allow the cleaning solution to soak in a few minutes; then wash the engine with a hose or wipe it dry with a cloth.

Remember the tool box too. Give it a good cleaning and oil the tools and wrap them in a cloth.

GREASE AND OIL

Carefully grease the tractor and check the lubricant level in all the gear cases. Oil the starter, generator, and other parts which need oiling.

CRANKCASE

Drain the engine crankcase. Clean or replace the oil filter. Remove the valve cover, clean this area, and flush the valves, springs, and rocker arms with motor oil. Refill the crankcase with new oil of the correct seasonal grade for service when the tractor will next be used. (If you have a diesel engine, change the oil in the injection pump.) Before storing is a good time to put clean fresh oil into the hydraulic system. Completely service the air cleaner.

RADIATOR

Drain the radiator and engine block and flush with clean water. You will thereby help prevent deposits from hardening in the cooling system. Drive the tractor into a dry shed. Drain the cooling system and tie the drain plugs to the steering wheel as a reminder to refill the cooling system before starting the engine. Some engine builders suggest the use of anti-freeze in the radiator of the tractor while it is in storage. The anti-freeze solution keeps the cooling system from rusting.

BATTERY

Remove and clean the battery. Add water to the battery cells to bring the electrolyte to the proper level. Charge the battery and store it in a cool, dry place where it will not be subject to freezing temperatures. The battery should be maintained in a fully-charged condition during storage. Check the specific gravity periodically and recharge the battery whenever necessary.



JACK IT UP

Take the load off the tires by jacking up the wheels. If you have a cultivating tractor, place an old sack between the front wheels to catch any grease that may fall on the tires. Inflate the tires to recommended pressure. Examine tires for cuts that may need repair.

Remove the spark plugs and place about two tablespoons of summer-weight motor oil in each cylinder. Turn the engine over several times to coat the cylinder walls with a film of oil.

DIESEL TRACTORS

When storing a diesel tractor you will need to protect the fuel system from rust and oxidation. Most special diesel fuels contain a rust protection additive. If you are using this type of fuel, fill the fuel tank to eliminate water condensation. If you are not using a fuel which contains a rust protection additive, drain the fuel tank and refill with a mixture of 1 gallon of 10W motor oil and 1 gallon of kerosene. Then start the engine and let it warm up until you are sure the entire fuel system is filled with the flushing fuel. Check your Operator's Manual to see which method is suggested for your tractor.

GASOLINE TRACTORS

If you have a gasoline engine, drain the fuel from the tank, the carburetor, and sediment bowl. Leave the drains open. Put a can over the exhaust stack to keep out moisture.

A gummy substance may form in gasoline if the gasoline is permitted to stand for an extended length of time. The gum will cause trouble by accumulating in the carburetor jets and passages. (Gum deposits can be dissolved with a mixture of one part alcohol and one part benzol, or with acetone.)

LP GAS TRACTORS

LP gas fuel becomes a vapor at atmospheric pressure. Therefore, when LP gas tractors are stored in a shed for the winter, special care must be taken to eliminate the possibility of leakage of fuel vapors that might cause a fire. When an LP gas tractor is to be stored for a long period of time, it is best to store the tractor with the fuel tank completely empty. Check with your dealer for instructions on how this can be done safely.

If storage is only for a short while, shut off both the vapor and liquid fuel valves and let the engine run out of fuel to stop itself. Always turn off both the liquid and vapor withdrawal valves on the fuel tank of any tractor left in storage in a building. Also, be sure the 80-percent full bleed valve is completely closed.

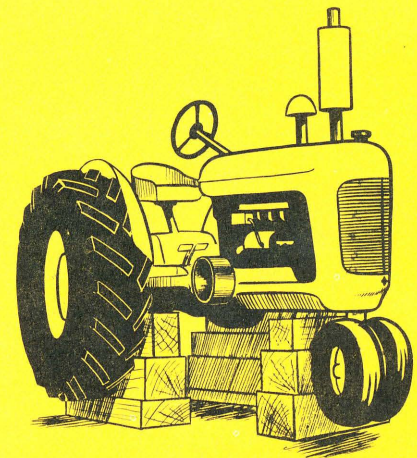

Fig. 5. Put your tractor up on blocks when you store it.

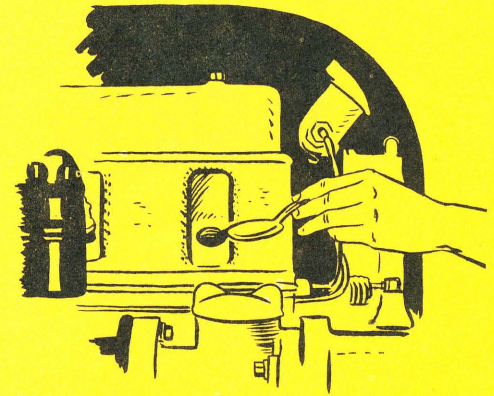

Fig. 6 Two tablespoons of oil in each cylinder guards against rust.

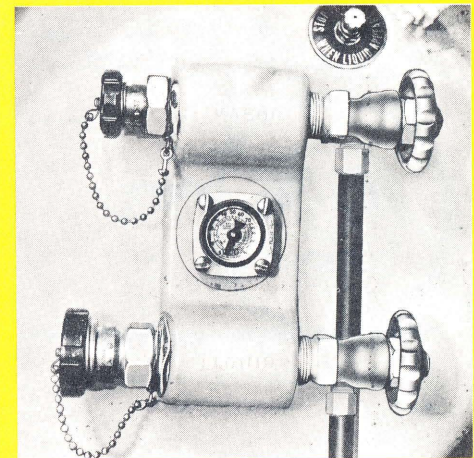

Fig. 7 LP gas tractors should be stored with an empty fuel tank.

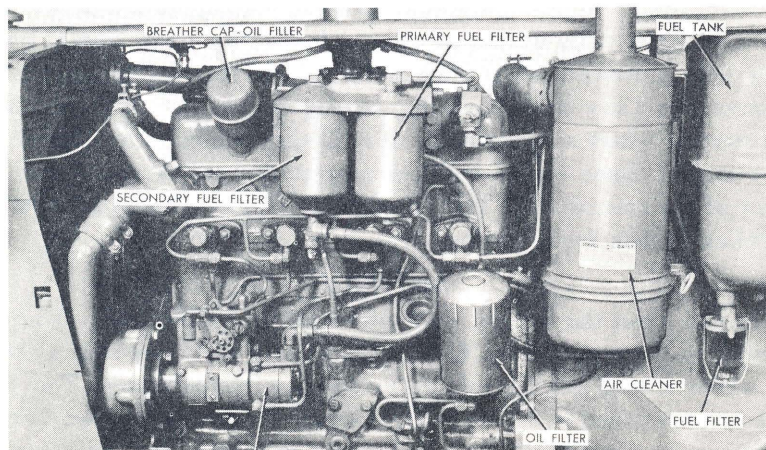

Fig. 9 Diesels have several filters and traps to drain and service.

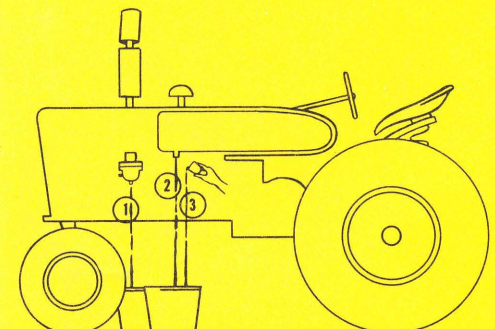

Fig. 8 Three places to drain a gasoline engine of fuel.

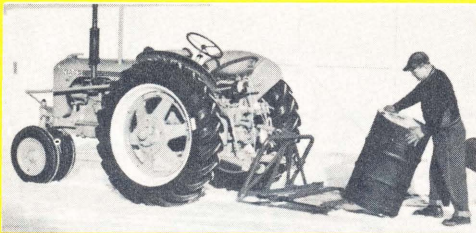

Fig. 10 If the tractor is used during winter— it must be protected.

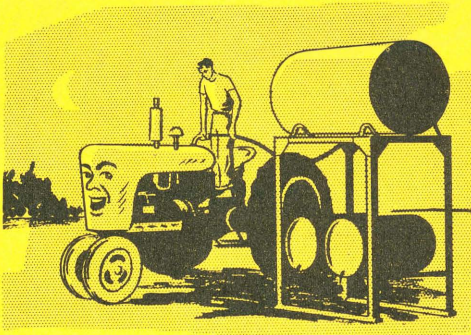

Fig. 11 Fill the tank in the evening.

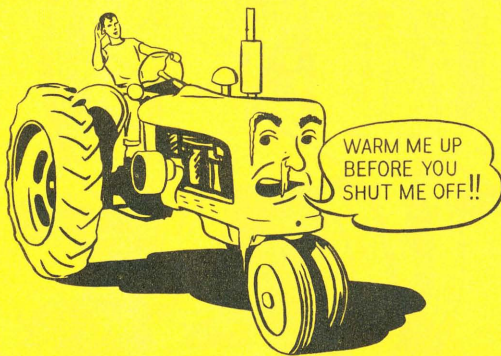

Fig. 12 Let the engine warm up before you shut it off.

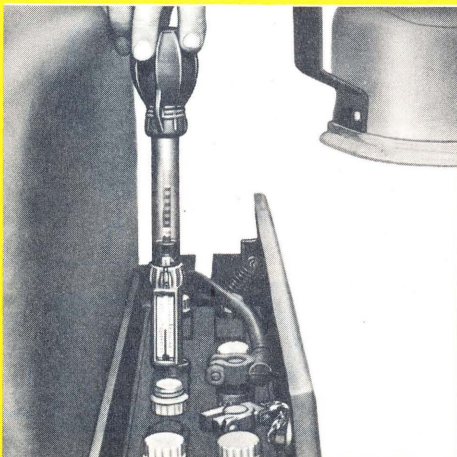

Fig. 13 Keep the battery charged—the best bet for quick starts on cold mornings.

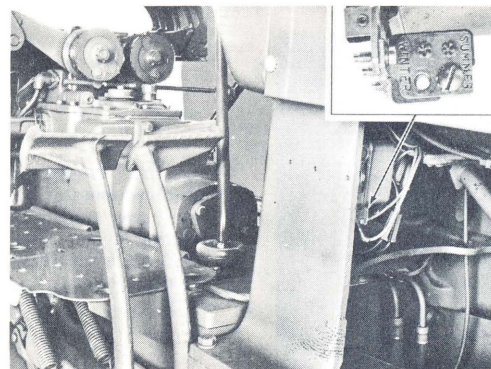

Fig. 14 This voltage regulator can be set for a higher charging rate in the winter.

PREPARING A TRACTOR FOR WINTER USE

If you plan to use your tractor through the winter, make sure that it is properly protected. Check your Operator's Manual for special instructions. Here are some good pointers to keep in mind.

Start with a good cleaning of the tractor so that it will not collect moisture and short out.

Clean the air cleaner and refill the cup with a winter grade of oil. Check the oil in the cup as often as you would in the summer, particularly if you are using the tractor for grinding. Also, you may find moisture collecting in the cup. Water gives oil a milky color.

Change the crankcase oil more often in the winter than you would in the summer to prevent sludge deposits. Every gallon of fuel burned in an engine produces a gallon of water. Some of the water collects in the crankcase where it mixes with crankcase deposits to produce sludge. Sludge can plug oil lines and ruin an engine. You can get rid of moisture in the crankcase by following one important rule. Once you start an engine, let it warm up and run at operating temperature for several minutes before shutting it off. This will get the crankcase hot and vaporize the water that condenses in the crankcase. The crankcase ventilation system will then push the vapors out of the engine.

Service all of the lubrication systems. Be sure to use a winter grade of lubricant when you refill. Fresh grease in the bearings will help to keep out moisture. This is particularly important for the front-wheel bearings.

Drain and flush the cooling system. Refill with a recommended antifreeze. If you have trouble getting the cooling system up to temperature, you may need to replace the thermostat.

Check all fuel filters, water traps, and sediment bulbs in the fuel system. They will need frequent attention in the winter to prevent water from collecting. Water will freeze in the fuel system and keep the engine from starting. Fill the fuel tank at night and let it run until the fresh fuel reaches the engine. This will provide fresh fuel for easier starting in the morning.

Give the electrical system a complete tune-up. Check the spark plugs, breaker points, distributor, and ignition wires. Keep the battery fully charged and your tractor will start quicker on a cold morning. You can use a low-current charger on the battery during the night to keep the battery warm and fully charged. The starter will then turn the engine over faster. This is especially important for diesels that require more cranking power because of their high compression ratios. Some tractors have an adjustment on the voltage regulator for increasing the generator charging rate in the winter time.



An alert driver can tell from the sound of an engine when something is wrong. As soon as he notices it, he should stop and try to find the trouble. If he can, he should fix it at once. He should not wait until he comes from the field or gets to the next repair shop unless he is sure driving won't damage the engine further.

A good operator knows whether the job needs a serviceman with special tools, just as you would decide whether or not you needed a doctor if you were sick. You might treat a simple backache yourself; but if you thought your trouble might be appendicitis, you would go to a doctor at once.

Trouble shooting means using your head. Use what you have learned about engines and machinery care. Your engine will run better and last longer.

What makes an engine run? First, there must be a proper mixture of fuel and air in the cylinder. This mixture must be compressed and ignited by a hot spark. (In a diesel engine, the fuel ignites by itself when injected into extremely hot air.) Then, after the power stroke of the piston, the cylinder must be cleared of the burned gases. This cycle—intake, compression, power, and exhaust—is repeated again and again.

When something goes wrong, figure out what should be taking place, but isn't. For example, black smoke from the exhaust stack will mean that the air-fuel mixture is too rich. Check the carburetor adjustment. A carburetor float valve may be sticking. A plugged air intake or stuck choke may be the trouble.

If you are having trouble with a faulty engine, you need to draw upon all of your experience and know-how. If you know your engine, you can find the trouble. Just be patient and work. Here are a few examples of trouble shooting. Notice, you start with what you know and check on what you do not know.

The electric starting motor does not turn the engine. Is the battery run down? Are the cables broken or frayed? Are the connections firm? Has the switch or solenoid gone bad? Has the starting motor burned out? Can you turn on the lights? Answering these questions will start you on your check.

Be sure you know how to use special devices for cutting down the load on the starting motor. Tractors with power shift transmissions often have a lever to momentarily disconnect the engine from a constant running hydraulic pump that operates the transmission.

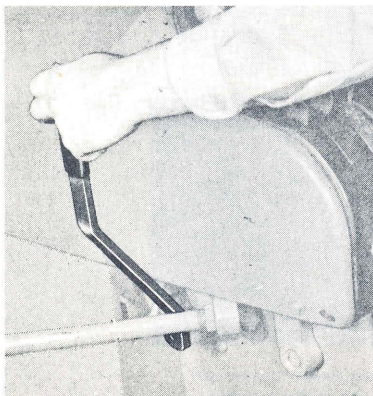

Fig. 18. Engine disconnect lever which momentarily frees the engine from the transmission during the starting cycle. This device is often used on tractors with power shift transmissions.

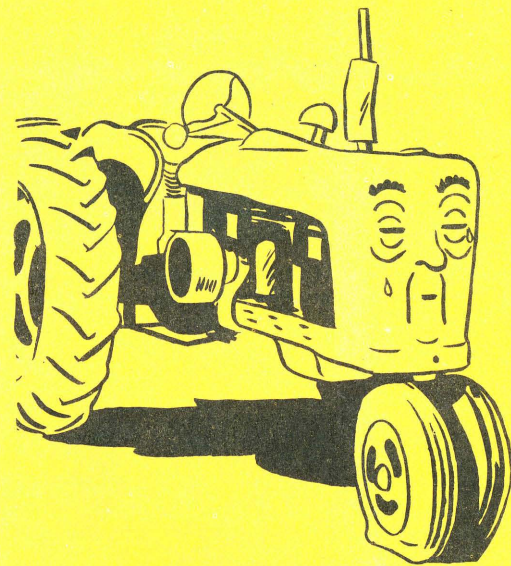

Fig. 15 An ailing tractor

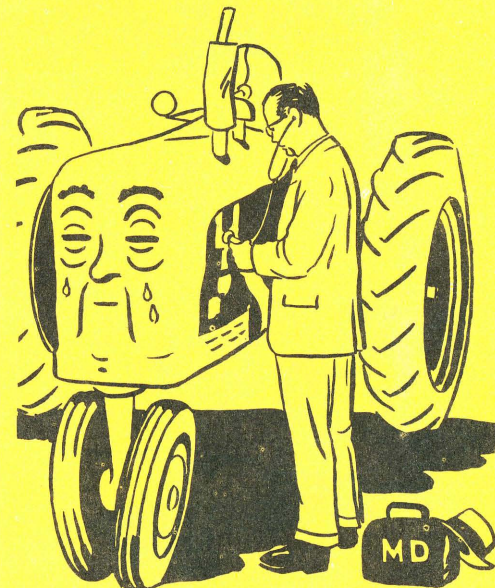

Fig. 16 needs a doctor.

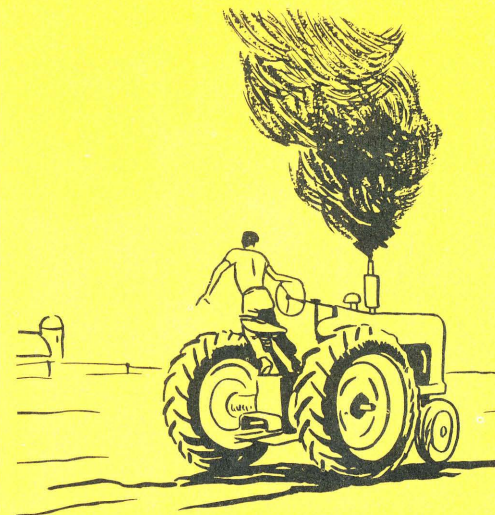

Fig. 17 Smoke signals may mean faulty carburetor adjustment.

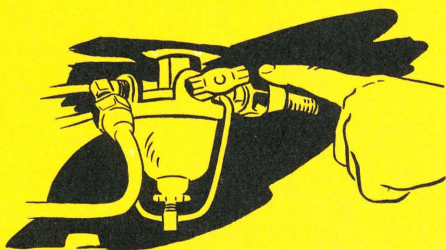

Fig. 19 Is the fuel tank valve turned on?

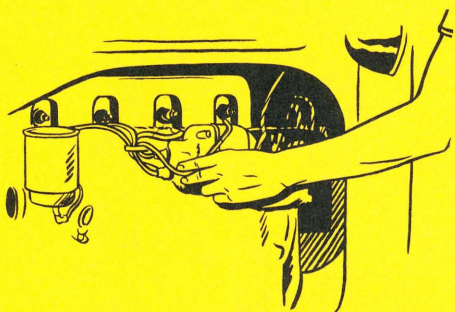

Fig. 20 Checking for a spark.



Fig. 21 Broken spark plug porcelain.

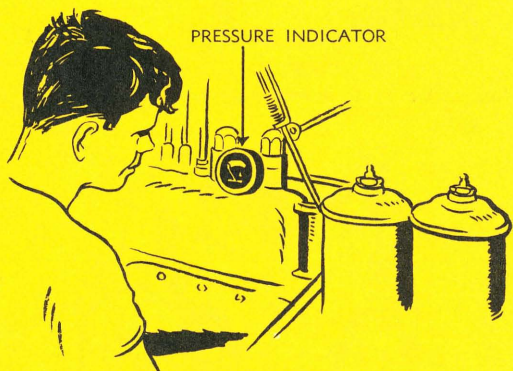

Fig. 22 You can check if the fuel filters are plugged by observing the pressure indicator.

If the engine fails to start, do you have fuel in the tank? Perhaps it is shut off. Is fuel getting to the carburetor? Is the air intake plugged? Disconnect the line at the carburetor or remove the sediment bowl. The fuel line may be plugged. Do you see water in the fuel? Perhaps the engine is flooded. Let it set a few minutes and try again without choking.

Check the ignition. When checking the ignition system, be sure that the switch is on. On engines using a magneto, the switch is a ground switch and must be opened for starting. For battery ignition, this switch must be closed to complete the circuit from the battery to the points in the distributor. After making sure that the switch is set right, remove a spark plug wire from one of the plugs and hold the wire about 1/8 inch from the engine head. Crank the engine. If a thick, hot spark jumps the gap the ignition system is working properly. Now take out the plug, attach the wire and hold the base of the plug against the block. Again crank the engine. If the spark jumps across the gap, the plug is not shorting out.

Is the spark plug firing? Possibly the porcelain is broken. Is the gap too wide or too close? Is the porcelain dirty or wet, shorting the spark? Are the points dirty or is the porcelain charred?

Does your diesel engine fail to start? Perhaps there is no fuel or the fuel is not turned on. Maybe the engine is not warm enough. Do you have strong compression? Are the valves or rings sticking? Do you have the right fuel? Is the air intake plugged? Lines to the injector may be plugged or not working. The injector may be out of time. The fuel filters may be plugged. Check the fuel bleed valves to eliminate air locks.

The engine seems to have lost power. Perhaps the fuel mixture is too rich or too lean. The engine may be out of time or the spark may be advanced or retarded too far. The air intake may be partly closed. The fuel line may be plugged with dirt. Is the choke stuck? The vent in the fuel cap may be closed with dirt. The manifold heat may be on. Check your Manual to learn how to fix these things. Is the float stuck in the carburetor? How is the engine compression? Turn the engine over by hand to check it. Perhaps the piston rings or valves are stuck. Are the intake manifold connections leaking? The clutch may be slipping. Perhaps you are running the engine at too low a speed in high gear (lugging).

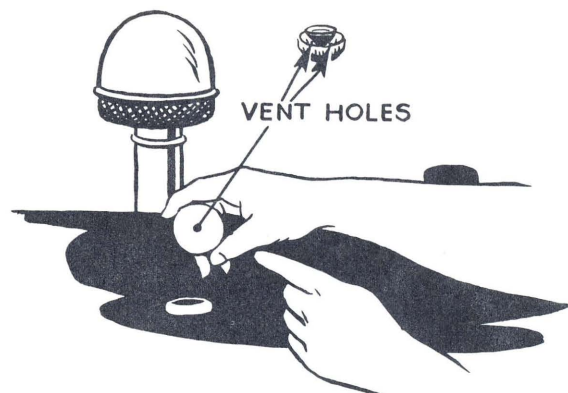

Fig. 23 Check the vents in your fuel cap. If plugged, they will restrict fuel flow.



Is the engine overheating? Perhaps the mixture is too lean. Check the fan belt for slippage. Are the radiator fins plugged with dirt? Perhaps the cooling system needs cleaning. The water pump may need overhauling. Perhaps you are running the engine too slowly in high gear. Is the radiator clean? Perhaps the thermostat is stuck. The timing may be off, too late, or too advanced. Use your Manual to check the timing. The radiator shutters may be partly closed. The insect screen may be cutting off air. The exhaust or muffler may be bent or partly closed. Do you hear excessive knocking? Perhaps the fuel octane is too low. The diesel injector may be off time.

The engine is knocking excessively. You may be using a low grade or low octane fuel. The spark may be advanced too far. There may be excessive carbon deposits in the engine. Check the plugs. They may be too hot for your engine and fuel. If the engine is using oil, the bearings may be loose.

The engine has weak compression. The valves may be stuck open. The rings may be stuck. You may have excessive wear in the cylinders because the air cleaner isn't working. Check the oil. Listen for hissing noises. You may have a blown head gasket.

Exhaust has black smoke. You have an over-rich mixture. Is the choke on? Is the carburetor set too rich? If it is a diesel, you are injecting too much fuel or perhaps the diesel injections may be late. The fuel may be too heavy for the engine. The diesel air intake may be plugged. Check the cleaner. You may be overloading the engine.

Exhaust has heavy blue smoke. The engine is burning oil. You may have poor compression. You may have too much oil in the air cleaner.

Engine is using too much oil. Perhaps the oil is diluted or too light in weight. Possibly the end-bearing seals are broken. Put a newspaper under the engine at night. Oil dripping on it will show the next morning. Loose bearings will cause the engine to use more oil than it should. So will broken rings and loose pistons. Are you carrying the oil level in the crankcase too high? Try adding oil only when it goes to the "fill" mark. Is the crankcase breather plugged? Perhaps the engine was not broken in properly.

Low oil pressure. Perhaps the gauge is faulty if the oil is not low. Is the oil thin? Does the engine have loose bearings? Possibly the line is broken and leaking. The pressure relief valve may be broken or sticking. The oil pump intake screen may be plugged.

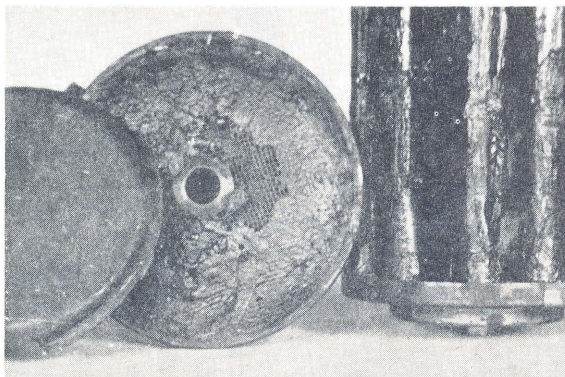

Fig. 28 Plugged oil pump intake screen; plugged oil filter.

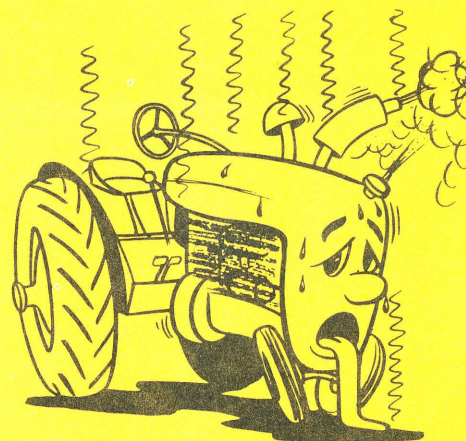

Fig. 24 Does the engine need water?

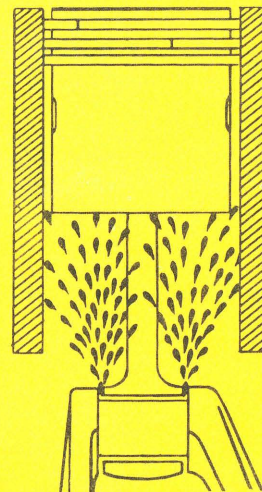

Fig. 25 Worn bearings can cause high oil consumption.

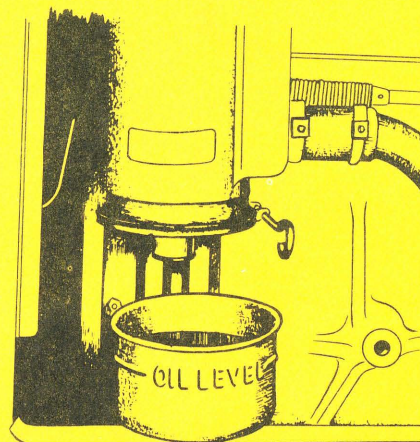

Fig. 26 Check the air cleaner of a diesel engine.

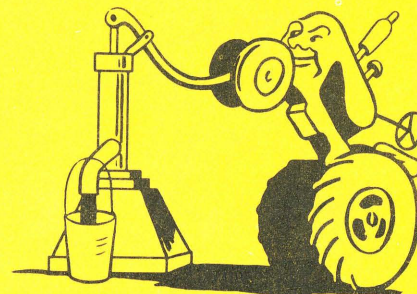

Fig. 27 Is your engine an "oil pumper"?



1. List the tractor and power units on your farm that need to be prepared for winter storage.

2. List the units you use during cold weather and need to winterize.

3. Prepare a tractor or power unit for winter storage or winter operation. Use your Operator's Manual as a guide. Fill in the blanks below to show what you did.

Part Serviced

Work Done

Part Serviced	Work Done
<hr/>	<hr/>
<hr/>	<hr/>
<hr/>	<hr/>
<hr/>	<hr/>
<hr/>	<hr/>
<hr/>	<hr/>
<hr/>	<hr/>
<hr/>	<hr/>
<hr/>	<hr/>
<hr/>	<hr/>
<hr/>	<hr/>
<hr/>	<hr/>
<hr/>	<hr/>
<hr/>	<hr/>
<hr/>	<hr/>
<hr/>	<hr/>
<hr/>	<hr/>
<hr/>	<hr/>
<hr/>	<hr/>
<hr/>	<hr/>
<hr/>	<hr/>
<hr/>	<hr/>
<hr/>	<hr/>

(Over)

TROUBLE SHOOTING

Try "fixing" an engine so others can "trouble shoot." Perhaps they would like to "fix" one so you can practice. Tell how you would go about checking out these troubles.

4. When you crank an engine with the starter, it fails to start.

a. List the checks you would make on fuel.

1. Gasoline in the tank? _____ 2. _____

3. _____ 4. _____

b. List the checks you would make on ignition.

5. The engine starts, but it "rolls," and black smoke is coming out of the exhaust. What would you look for?

6. The engine is running, but you notice it is hitting on only three cylinders. How would you find the one missing? _____

7. After the engine has operated for about 20 minutes, you notice the radiator is boiling. What would you check? _____

8. A neighbor complains that his tractor has lost its power to pull. He says, "The engine is worn out." You know he is a careless person. What do you look for about the tractor to find the trouble?

9. Have someone put "troubles" in a tractor engine and you try to locate them. Write down what the "symptoms" were and what the trouble proved to be:

Symptoms

Trouble

_____	_____
_____	_____
_____	_____
_____	_____

Note: Fill out this work unit, using your own tractor at home. Be ready to discuss your experiences with other 4-H members at your next club meeting.



THIRD YEAR UNIT 7

WINTER CARE

Place the letter for the correct answer at the right of the page.

1. Winterizing of engines should be done: (A—only on those that will stand idle for more than a month at a time) (B—only on gasoline tractor engines) (C—on all tractor and other farm engines). _____
2. When tractors are to be used for light work during the winter months it is best: (A—not to winterize them) (B—to run them with the same lubricants and greases that were used during the fall so that the motor will not have to “break in” new lubricants during cold weather) (C—to change to winter-grade lubricants). _____
3. When winterizing a tractor: (A—seal the tool box so snow won't sift in and rust the tools) (B—remove all tools from the box so they can be used in the basement or tool shed) (C—clean the tool box and tools; oil the tools and wrap them in a cloth). _____
4. In following a winterizing procedure: (A—leave the used oil in the crankcase so that the crankshaft remains well coated all winter) (B—drain and flush the crankcase and replace the plug immediately so that no dirt or dust can blow in) (C—drain the crankcase and refill with new oil of the correct seasonal grade, operating the tractor long enough to circulate the oil). _____
5. If a tractor, equipped with pneumatic tires, is jacked up for the winter in a shed: (A—inflate the tires to 25 pounds more than normal pressure) (B—inflate the tires to recommended pressure) (C—deflate the tires). _____
6. In winterizing an engine of a tractor that will stand idle all season, drain and flush the radiator and: (A—close the drains or petcocks so no dirt will blow in) (B—refill the radiator with good antifreeze solution) (C—leave the drain plugs out). _____
7. In winterizing a tractor for storage, remove the spark plugs and: (A—clean the plugs before storing them, stuffing the holes with clean cloths to keep dirt out of the cylinders) (B—clean the plugs, soaking them in light oil before replacing them) (C—clean the plugs, place about two tablespoonfuls of heavy motor oil in each cylinder, and turn the engine over a few times before replacing the plugs). _____
8. When a tractor is prepared for winter storage, it is best: (A—to fill the fuel tank and seal it so no evaporation can occur) (B—to drain the tank, sediment bowl, and leave all drain cocks open) (C—to leave the tank half full so there is room for expansion of the cold fuel). _____
9. In winterizing a tractor the battery should be: (A—drained) (B—fully charged and left in the tractor) (C—fully charged and stored indoors). _____
10. Moisture will condense faster in a fuel tank when it is (A—full) (B—empty). _____

TROUBLE SHOOTING

Place the letter for the correct answer at the right of the page.

1. When you are trouble shooting, you: (A—use what you have learned and look for the cause of the trouble) (B—guess where the trouble is and keep trying everything). _____
2. When something goes wrong with the engine the first thing you do is: (A—call a serviceman to fix the trouble) (B—figure out what might have gone wrong and see if a serviceman is needed). _____
3. If the tractor is hard to keep running and the flow of fuel from the tank to the carburetor is slow, it may be that: (A—the carburetor float is stuck) (B—the sediment bowl screen is plugged). _____
4. In checking the ignition system on a tractor using battery ignition be sure the switch is: (A—open for starting because it is a ground switch) (B—closed to complete the circuit from the battery to the breaker points). _____
5. If the engine runs jumpy and the intake manifold leaks: (A—check the cooling system) (B—replace gaskets and tighten the manifold). _____
6. If the tractor develops a lack of power and the timing is found to be incorrect: (A—have a serviceman repair the governor) (B—check the timing according to your Operator's Manual). _____
7. If the engine overheats and the fan belt is slipping: (A—check the tension on the fan belt and adjust or replace with a new belt) (B—clean the blades of the fan). _____
8. Low oil pressure caused by worn bearings should be corrected by: (A—using a heavier grade of oil) (B—replacing the bearing inserts with new ones). _____
9. A higher reading of the oil pressure gauge means: (A—there is pressure on the line from the pump to the gauge) (B—that the entire lubrication system is getting oil). _____
10. If the generator does not charge and the brushes are found to be worn: (A—use coarse sandpaper on the brushes to roughen them) (B—have a serviceman make repairs). _____

Note: This Check-Up Sheet is intended to test what you have learned and to stimulate discussion with the other members. The more you discuss these questions with your leader and the other members the more you learn.



COST OF OWNING A TRACTOR

In the Second Year Project you learned how to determine operating costs with the help of the records that you kept. These operating costs included charges for fuel, oil, grease, and repairs. There are also fixed costs. We call them fixed costs because they include the annual costs of owning a tractor and are affected very little by the amount the tractor is used. Fixed costs include: (1) depreciation (2) interest on money invested in the tractor (3) insurance (4) taxes, and (5) housing.

There isn't an easy way for you to know exactly how much each of these fixed costs would be for your tractor. But if you know how much the tractor cost when it was new, you can make an estimate of costs with the help of some methods that have been worked out for that purpose.

Following is a brief description of these costs and an explanation of how they can be estimated. To make it easier for you to follow, we will show you what each of these costs would be for a tractor costing \$5,000. You will notice that each cost is based on a certain percentage of the purchase price.

Depreciation

As you continue to own your tractor its value keeps going down. Several methods can be used to determine this cost but we will use the *straight-line* method. It will give us the average depreciation for each year the tractor is owned until it is completely worn out. Assume a 15-year life and a 10-percent salvage value.

$$\text{Annual depreciation} = 6\% \text{ of purchase price}$$

The average depreciation for a tractor costing \$5,000 is 6 percent of \$5,000, or \$300.

Interest on investment

Interest is charged on money spent for the tractor, even if money is not borrowed for that purpose. If the money had not been spent on the tractor it could have earned a return as an investment elsewhere.

Let's figure the interest charge for our \$5,000 tractor with the interest rate at 6 percent—

$$\begin{aligned} \text{Annual interest charge} &= \frac{1}{2} \text{ of purchase price} \times \text{interest rate} \\ &= \frac{1}{2} \text{ of } \$5,000 \times 6\% = \$150 \end{aligned}$$

We used one-half of the purchase price because that is the average value of the tractor during its life.

Insurance

If the tractor is insured, then the regular insurance rates would apply. If the tractor is not insured, then a risk charge is made on the same basis. Again, we use one-half of the purchase price as the average value. A common insurance rate is 50 cents a year for each \$100 value.

Let's figure the insurance charge for our \$5,000 tractor with an insurance rate of 50 cents per \$100 value.

$$\begin{aligned} \text{Annual insurance charge} &= \frac{1}{2} \text{ of purchase price} \times \text{insurance rate.} \\ &= \frac{1}{2} \text{ of } \$5,000 \times .50 = \$12.50 \end{aligned}$$

Taxes

Farm machinery is taxed at the same rate as other farm property. Tax rates vary widely, depending on where you live. A simple method is to estimate your annual tax cost at 1 percent of the purchase price.

$$\text{Annual charge for taxes} = 1\% \text{ of purchase price.}$$

The annual charge for taxes on our \$5,000 tractor is 1 percent of \$5,000 or \$50.

Housing

If you store your tractor in a shed, part of the costs of the shed should be charged against the tractor. If you leave your tractor outside, it will wear out quicker. Thus we make a charge for housing whether the tractor is stored in a shed or not. Again, this charge varies, but the annual housing cost can be estimated at 1 percent of the purchase price. The annual charge for housing our tractor is 1 percent of \$5,000, or \$50.

Now let's add up all of the annual fixed costs for our \$5,000 tractor.

Depreciation	\$300.00 = 6.00%	of purchase price
Interest	150.00 = 3.00%	" " "
Insurance	12.50 = 0.25%	" " "
Taxes	50.00 = 1.00%	" " "
Housing	50.00 = 1.00%	" " "
Total	\$562.50 = 11.25%	of purchase price

If the tractor were used 600 hours a year the fixed cost per hour would be \$562.50 divided by 600, or about \$.94 an hour. By adding the operating cost to this figure we would get the total cost per hour for our tractor. Suppose we spent \$612 for operating cost including repairs. That gives an operating cost of \$1.02 per hour. Adding \$.94 an hour fixed cost to the \$1.02 operating cost gives a total cost per hour of \$1.96.

You can use the last page of the yellow unit to determine these costs for your tractor.

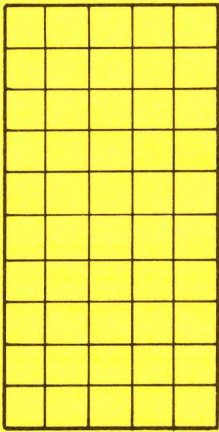

550 HRS.

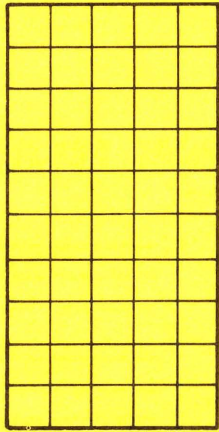

600 HRS.

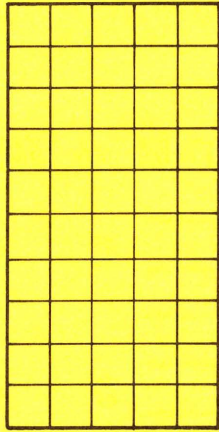

650 HRS.

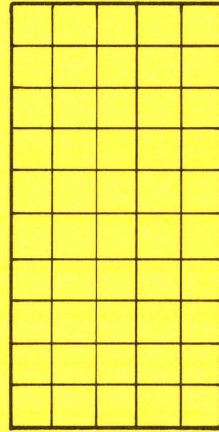

700 HRS.

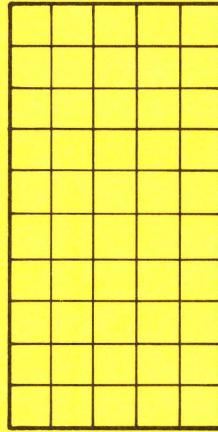

750 HRS.

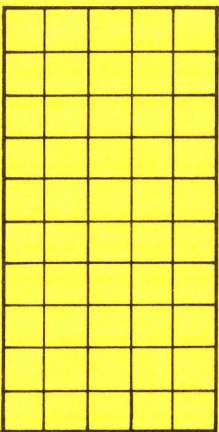

800 HRS.

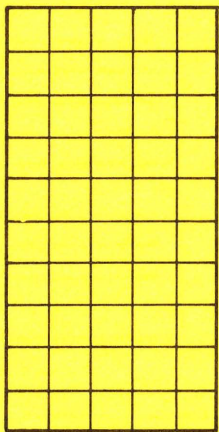

850 HRS.

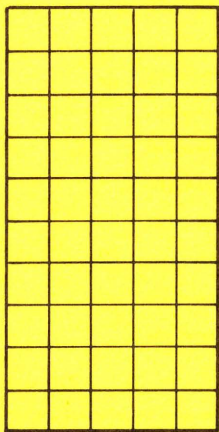

900 HRS.

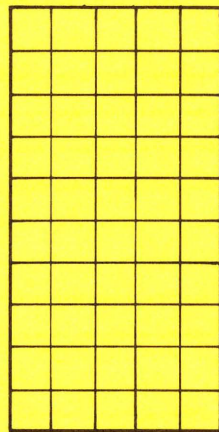

950 HRS.

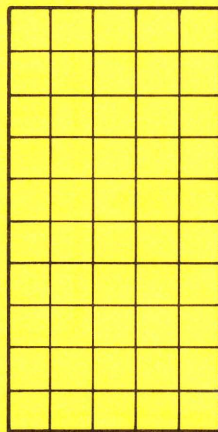

1,000 HRS.

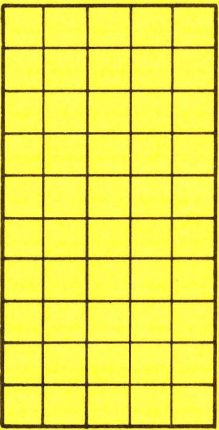

1,050 HRS.

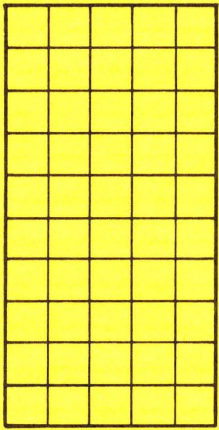

1,100 HRS.

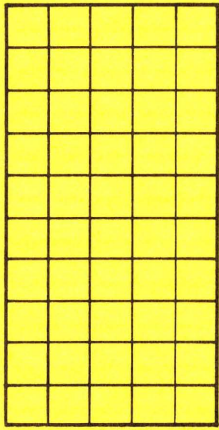

1,150 HRS.

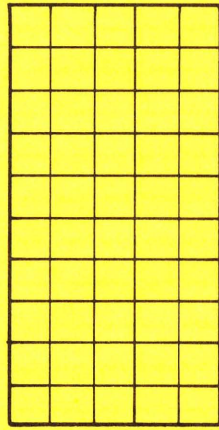

1,200 HRS.

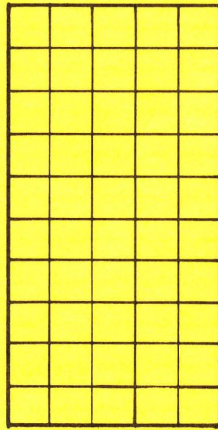

1,250 HRS.



Keep a daily record of your tractor's use, fuel, oil, grease, and repair costs for 1 month or longer. The longer you keep these records the more accurate your cost estimates will be.

Based on the records you have kept and using the information on fixed costs, estimate the costs for owning and operating your tractor. If you are not certain about repair costs, take 4 percent of the purchase price of your tractor. For instance, if your tractor costs \$5,000 you would average about \$200 each year for repairs.

Beginning date of records _____ Ending date _____

Number of hours tractor was used during time records were kept _____

Estimated number hours your tractor is used each year _____

Make of tractor _____ Model _____ Purchase price _____

Estimate costs on the basis of one year and list below:

Operating costs	Fixed costs
Fuel _____	Depreciation _____
Oil _____	Interest _____
Grease _____	Insurance _____
Repairs _____	Taxes _____
	Housing _____
TOTAL _____	TOTAL _____

What is the operating cost per hour for your tractor? _____

What is the fixed cost per hour for your tractor? _____

What is the total cost per hour for your tractor? _____

What is the total annual cost for your tractor? _____

Note: Fill out this work unit, using your own tractor at home. Be ready to discuss your experiences with other 4-H members at your next club meeting.

THIRD YEAR

MY ACHIEVEMENTS AND EXPERIENCES IN THE 4-H TRACTOR CARE AND SAFETY PROJECT

WHAT TO WRITE

In telling the story of your work in the 4-H Tractor Care and Safety Project you might give the reasons you decided to enroll in the club, the number of meetings you attended, and the demonstrations you gave. If you were an officer of the club describe your duties and how you carried them out. Mention any special awards or recognition you received for your work. How many hours did you spend on maintenance work during the club year? Tell about people who assisted you or people to whom you gave assistance. What part of the program was the most interesting to you?

(continued on next page)

